

# DSIA JOURNAL

A Quarterly Publication of the Defense Systems Information Analysis Center

Volume 6 • Number 2 • Spring 2019

A Titanium-Based Igniter System for

# HAND-GRENADE FUZZES

PAGE 4

ADDITIVE MANUFACTURING  
FOR AEROSPACE MAINTENANCE  
AND SUSTAINMENT

PAGE 12

MICRODIODE LASERS: A  
SAFER ALTERNATIVE FOR  
ELECTRICALLY-FIRED  
ENERGETIC DEVICES

PAGE 18

PAGE 25

LASER POWER BEAMING

PAGE 30

RANDOM ERROR IN SMALL-CALIBER  
DISPERSION



Distribution Statement A: Approved for  
public release; distribution is unlimited.



VOLUME 6 | NUMBER 2 | SPRING 2019

**Editor-in-Chief:** Brian Benesch

**Copy Editor:** Maria Brady

**Art Director:** Melissa Gestido

**On the Cover:**

*M67 Fragmentation Grenade*  
(Source: U.S. Army)

The DSIAC Journal is a quarterly publication of the Defense Systems Information Analysis Center (DSIAC). DSIAC is a DoD Information Analysis Center (IAC) sponsored by the Defense Technical Information Center (DTIC) with policy oversight provided by the Office of the Under Secretary of Defense (OUSD) for Research and Engineering (R&E). DSIAC is operated by the SURVICE Engineering Company with support from Georgia Tech Research Institute, Texas Research Institute/Austin, and The Johns Hopkins University.

Copyright © 2019 by the SURVICE Engineering Company. This journal was developed by SURVICE under DSIAC contract FA8075-14-D-0001. The Government has unlimited free use of and access to this publication and its contents, in both print and electronic versions. Subject to the rights of the Government, this document (print and electronic versions) and the contents contained within it are protected by U.S. copyright law and may not be copied, automated, resold, or redistributed to multiple users without the written permission of DSIAC. If automation of the technical content for other than personal use, or for multiple simultaneous user access to the journal, is desired, please contact DSIAC at 443.360.4600 for written approval.

Distribution Statement A: Approved for public release; distribution is unlimited.

ISSN 2471-3392 (Print)  
ISSN 2471-3406 (Online)



## CONTENTS

- 4** Additive Manufacturing for Aerospace Maintenance and Sustainment ▶  
AM Advanced Materials

---

- 12** Microdiode Lasers: A Safer Alternative for Electrically-Fired Energetic Devices ▶  
EN Energetics

---

- 18** A Titanium-Based Igniter System for Hand-Grenade Fuzes ▶  
WS Weapon Systems

---

- 25** Laser Power Beaming ▶  
DE Directed Energy

---

- 30** Random Error in Small-Caliber Dispersion ▶  
WS Weapon Systems

## CONTACT DSIAC

**Ted Welsh**  
DSIAC Director

**Brian Benesch**  
DSIAC Technical Project Lead

**DSIAC HEADQUARTERS**  
4695 Millennium Drive  
Belcamp, MD 21017-1505  
**Office:** 443.360.4600  
**Fax:** 410.272.6763  
**Email:** [contact@dsiac.org](mailto:contact@dsiac.org) ▶

**WPAFB SATELLITE OFFICE**  
704 TG/OL-AC/DSIAC  
2700 D Street, Building 1661  
Wright-Patterson AFB, OH 45433-7403  
**Office:** 937.255.3828  
**DSN:** 785.3828  
**Fax:** 937.255.9673

**DSIAC CONTRACTING OFFICER REPRESENTATIVE**

**Peggy M. Wagner (COR)**  
704 TG/OL-AC  
2700 D Street, Building 1661  
Wright-Patterson AFB, OH 45433-7403  
**Office:** 937.255.6302

**DSIAC PROGRAM MANAGEMENT ANALYST**

**Emese Horvath**  
IAC Program Management Office (DTIC-I)  
8725 John J. Kingman Road  
Fort Belvoir, VA 22060  
**Office:** 571.448.9753

## MESSAGE FROM THE EDITOR



By Brian Benesch

The DSIAC Journal is designed to complement the mission of the DoD Information Analysis Center (IAC) in eliminating redundancy, fostering collaboration, and stimulating innovation within the DoD research and associated science and technology (S&T) ecosystem. It facilitates information sharing and promotes a greater awareness of relevant DoD S&T developments.

The journal features findings and summaries of recent S&T research projects/programs highlighting related advancements or emerging trends. Ideally, readers who were, or are, planning to engage in comparable research efforts will be able to leverage published journal information to benefit their research efforts to streamline the realization of solutions to Warfighter challenges. Redundant research efforts can be avoided if researchers, scientists, and engineers share their work through publication platforms like the journal. To be sure, it is a lofty goal to *eliminate* redundancy, but that is the aim of the DoD IAC. Lack of awareness or an ill-informed DoD research community should not be the reason to repeat work.

How does the journal foster collaboration? Ideally, defense scientists are not conducting duplicative research efforts but efforts that complement one another instead. As with the goal of combating redundancy, the key is information sharing that facilitates awareness (e.g., by publishing in the DSIAC Journal). The more that researchers across all domains and military branches know, the greater the opportunity for collaboration.

An example was recently evidenced through a collaborative connection that we were able to make on account of the DSIAC Journal. Our Summer 2018 issue featured an article by Dr. Christopher Seedyk, a computer engineer with the U.S. Army Research Laboratory, on “Characterizing Cyber Intelligence as an All-Source Intelligence Product.” A few months after publishing this issue, we received a message from a technical advisor (who conducts corresponding research) with the Air Force Life Cycle Management Center seeking further information from Dr. Seedyk. We were able to facilitate an introduction to each researcher across military branches, thus fostering collaboration through this journal publication.

Finally, the DSIAC Journal can stimulate innovation by simply sharing novel research findings or highlighting emerging S&T that informs and inspires other scientists/engineers. Specifically, because the journal publishes articles on topics across multiple disciplines, reading a variety of topics presents opportunity for innovation. For example, this issue features an article on “Laser Power Beaming,” which may be an enabling technology for certain types of autonomous systems discussed in past journal issues. Although these are distinct articles from different focus areas (directed energy and autonomous

The DSIAC Journal can stimulate innovation by simply sharing novel research findings or highlighting emerging S&T that informs and inspires other scientists/engineers.

systems, respectively), there may be an innovative and collaborative opportunity between the two topics, such as integrating a laser power-beaming system into an autonomous system. In any case, the more one reads about scientific and technological topics as presented in this journal, the more one’s imagination will be cultivated.

I trust that you find the articles in this Spring 2019 issue interesting and applicable to your work efforts. Perhaps you will discover that an effort you intended to conduct has relevant historical and/or ongoing research. Perhaps you will learn about research efforts that might complement with your own efforts, and you can find ways to collaborate. Even if a given article may not apply to your work, I hope that you will read and share it so that you and others throughout the greater DoD S&T ecosystem stay informed and encouraged to advance research toward the associated realization of solutions for Warfighter capability requirements. ■

# ADDITIVE MANUFACTURING

## for Aerospace Maintenance and Sustainment

By Ashley Totin, Eric MacDonald,  
and Brett Conner

### INTRODUCTION

**A**dditive manufacturing (AM) is causing a fundamental manufacturing paradigm shift that is changing how aircraft are now maintained and sustained. Sustaining an aging aerospace fleet is an enormous challenge. The U.S. Department of Defense maintains nearly \$100 billion worth of spare parts and has to balance avoiding excess inventory [1] while simultaneously preventing stock-out [2]. A large 747-type aircraft can have nearly 6 million individual parts produced by a global supply chain of approximately 550 companies, some of which may not exist a decade from now [3]. Sustainment organizations struggle with long lead times, resulting in maintenance delays or grounded aircraft. For example, the Oklahoma City Air Logistics Complex reported lead times as long as 800 days for constant speed drive castings [4]. Meanwhile, at the end of 2016, 29% of all U.S. Marine Corps

F/A-18 Hornets were grounded pending spare parts [5].

AM emerged as a potential solution to reduce both lead times and inventory costs. The technology is well suited for fabricating low-volume, customized, and complex components [2, 6–8]. An analysis of the global aerospace maintenance, repair, and overhaul market identified that if 15% of replacement parts could be produced with AM, over \$1 billion in materials and transportation-related savings could be realized; commercial airlines would see \$250 million in additional liquidity as a result of reduced inventory costs [9]. Moreover, these analyses were only predicated on printed replacement parts and did not include the additional benefits of three-dimensional (3D) printed tooling, fixtures, jigs, or prototypes [9].

AM is also beneficial for part count reduction and weight savings. Since AM creates parts layer by layer, complex shapes can be designed and fabricated. This would not be possible with conventional methods [7]. For example, a geometrically-complex part fabricated traditionally may be designed as multiple parts which are then joined or assembled. Alternatively, by using AM, this assembly can be consolidated into a single piece and reduce assembly costs. Another example would be reducing the part's weight by only depositing material where it is required for strength and stiffness. Mathematical tools can optimize the topology (i.e., shape) [10] or integrate lattice structures [11] in order to reduce weight without compromising performance.

The aerospace, medical, and automotive industries adopted AM early [12]. In 2017, the aerospace sector comprised nearly 19% of the AM market [13]. In the U.S. Air Force, the three air logistics complexes integrated AM into aircraft

maintenance and sustainment efforts [14]. The U.S. Navy concluded that \$1.49 billion would be saved annually on staffing and organizational costs by applying AM within maintenance programs [15]. Companies such as Boeing, Lockheed Martin, General Electric, and Airbus demonstrated how AM can reduce lead times, component weight, operational costs, and environmental impacts [16]. General Electric (GE) invested \$1.5 billion in AM, including research and development, implementing 3D printing technology, and production [17].

## AM PROCESSES AND AEROSPACE MATERIALS

Seven AM process categories [18] have been identified, and various materials can be fabricated through AM in each (see Table 1 and Figure 1). The resulting mechanical performance has improved due to advanced materials and improving manufacturing processes. Lightweighting is critical for aerospace structures. Lightening plate and web structures through traditional machining from thick billet requires an estimated 6 lbs of billet needed for every 1 lb of material contained within the final part

(or a 6:1 “buy-to-fly” ratio) [19]. AM produces near net shape parts, resulting in significantly reducing this ratio [20].

A diversity of materials can be made using AM, including polymers, metals, ceramics, sand, paper, and composites [13, 21–23]. Materials and processes most relevant to aerospace maintenance and sustainment are shown in Table 2.

## APPLICATIONS SPECIFIC TO AEROSPACE MAINTENANCE AND SUSTAINMENT

With the multiple AM processes and functional materials available, the aerospace industry is using the technology for many applications specific to maintenance and sustainment. The next subsections explore how the aerospace sector is currently using AM.

### Prototyping

One of the original applications for AM is rapid prototyping for fit checks, with significant utility in aerospace maintenance and repair [36]. For example, Fleet Readiness Center (FRC) Southwest created a prototype of a tub-fitting reinforcement. Once the fit was verified, the part was machined

Table 1: Process Categories of AM as Defined by ISO/ASTM 52900-15 [18]

PROCESS	DEFINITION
Vat Photopolymerization	Liquid photopolymer in a vat is selectively cured by light-activated polymerization.
Material Extrusion	Material is selectively dispensed through a nozzle or orifice.
Powder Bed Fusion	Thermal energy selectively fuses regions of a powder bed.
Binder Jetting	A liquid bonding agent is selectively deposited to join powder materials.
Material Jetting	Droplets of build material are selectively deposited.
Directed Energy Deposition	Focused thermal energy is used to fuse materials by melting as they are deposited.
Sheet Lamination	Sheets of material are bonded to form a part.

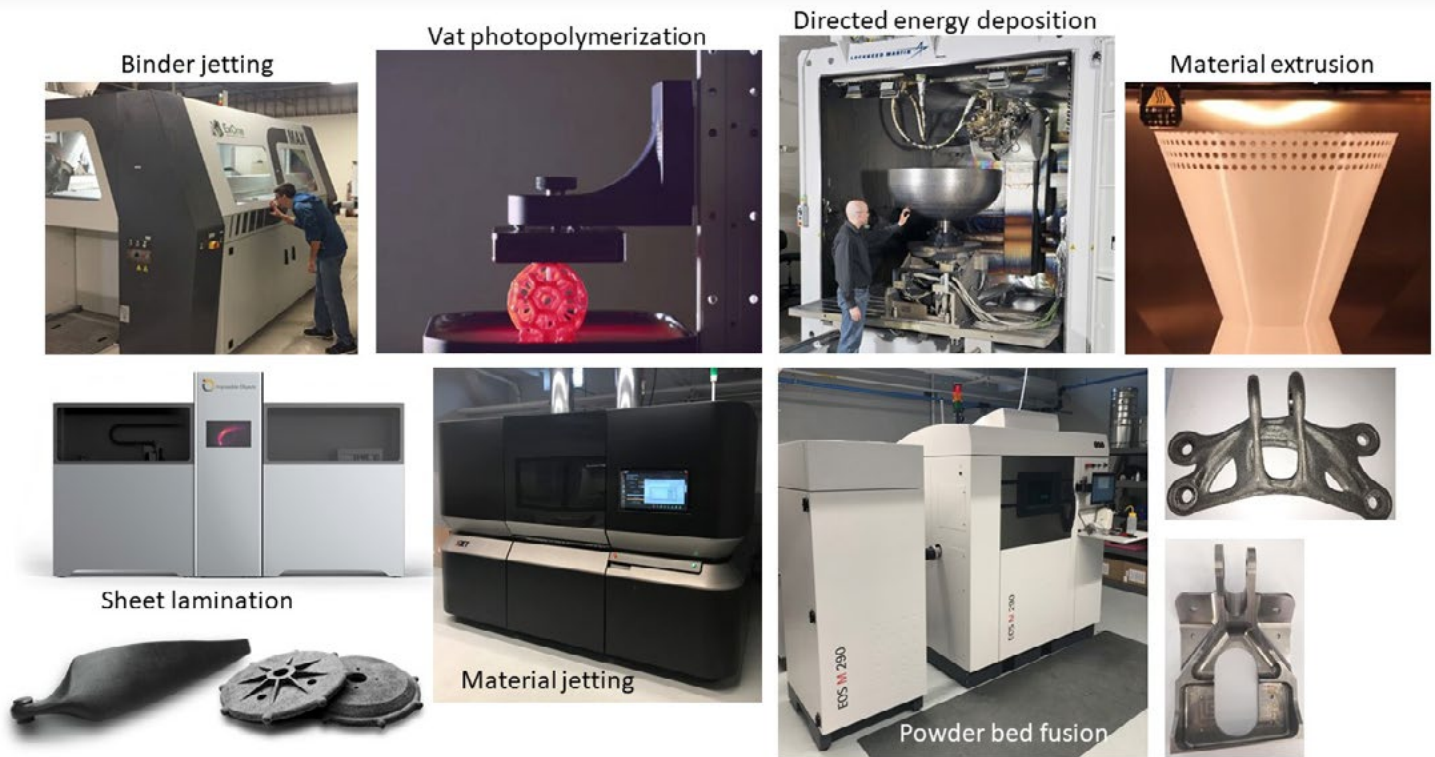

Figure 1: Examples Representing Each of the ASTM/ISO 52900-15 Categories of AM Equipment (Sources: *Carbon and Impossible Objects*, Youngstown State University and University of Texas at El Paso).

Table 2: Aerospace Relevant Materials Produced Using Additive Manufacturing

MATERIAL TYPE	AM PROCESS	MATERIALS	SOURCES
Polymers	Material extrusion	Acrylonitrile butadiene styrene, polycarbonate, ULTEM 9085, polyphenylsulfone, high-impact polystyrene, and polyethylene terephthalate	[13, 24–26]
	Powder bed fusion (i.e., selective laser sintering)	Polyamide 11 and 12 (including fire-resistant varieties), polyetherketoneketone, and polyetherketoneketone	[13, 27, 28]
Composites	Material extrusion	Chopped carbon fiber-filled AB; carbon fiber (CF)-filled nylon; and CF-filled nylon reinforced by continuous Kevlar, fiberglass, or CF	[29, 30]
	Sheet lamination	Printed layups of Kevlar, fiberglass, and CF	[31]
Metals	Powder bed fusion and directed energy deposition	Tool steels, stainless steels, titanium alloys (i.e., Ti-6Al-4V), aluminum alloys (generally, Al-Si-Mg and not yet 2000, 6000, or 7000 series), nickel-based alloys (i.e., Inconel 625 or 718), cobalt-chromium alloys, copper-based alloys, platinum, palladium, tantalum, and high-entropy alloys	[13, 32–34]
	Binder jetting	Stainless steels, tool steels, titanium alloys	[13, 35]
	Sheet lamination	Most metals found in sheet or foil form, including aluminum, stainless steel, tantalum, nitinol, and copper	[13]

out of aluminum [37]. As computer numerical control (CNC) machining is time consuming, relatively labor-intensive (especially for programming), and possibly capacity-constrained, AM prototypes (Figure 2) can prevent waste due to incorrect geometries or dimensional tolerances.

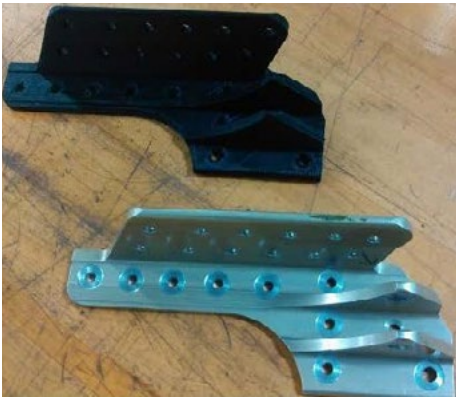

Figure 2: A Drill Guide Built With a Desktop Material Extrusion Printer (Source: Darrell Wallace).

### Tooling, Fixtures, and Jigs

The “low-hanging fruit” of AM is the reduction in cost and time for aerospace maintenance and sustainment through fabricating tooling, fixtures, and jigs. The benefits can be realized nearly immediately without the qualification and certification challenges associated with AM end-use parts. For each aerospace vehicle, hundreds of fixtures, guides, templates, and gauges can be printed with AM, reducing cost and lead time by 60–97% [38, 39]. An industrial supplier for composite parts has identified 79% savings in cost and 96% savings in lead time by replacing CNC machining with material extrusion to produce tooling [40].

In addition to cost and lead-time savings, AM tooling can be large. In 2016, Oak Ridge National Laboratory (ORNL) produced a 777X composite wing trim and drill guide using Big Area Additive Manufacturing, as shown in

Figure 3. At that time, the structure was the largest 3D printed object ever and leveraged the carbon-reinforced polymer processing from ORNL [41].



Figure 3: One of the Largest AM-Produced Parts in the World (Source: Oak Ridge National Laboratory).

Military maintenance and sustainment organizations have also leveraged AM for tooling. Since 2006, the FRC-East Cherry Point has supported the fleet by using AM to create custom tooling [42] and demonstrated material extrusion printed tooling for sheet metal press and stretch forming and composite layup tooling [26]. AM tooling was used to return an AV-8B to flight that was damaged during a hard landing at sea, with polycarbonate material extrusion tooling used to press form sheet metal doublers required for the repair [26].

Aerospace metal castings can also take advantage of AM tooling in an industry where lead times of 10–12 months are common [43]. A team from Autodesk and Aristocast designed a modulating matrix structure for an investment casting pattern to cast a super-light airplane seat frame (shown in Figure 4). The computer-optimized, lattice structure provided a 35% lighter seat while meeting performance

specifications. The frame was cast in magnesium, resulting in a total weight savings of 56% compared to conventional aluminum subtractive manufacturing.



Figure 4: An AM-Enabled Magnesium Investment Casting of an Airbus Seat Frame (Source: Autodesk).

Binder jetting is used to create tooling for sand casting. When AM is used for core fabrication, material scrap can be reduced by 90% compared to traditional manufacturing [44]. Other benefits of AM sand casting are reductions in lead time and cost, improved functionality, and increased customization [44]. AM

for casting tooling improves lead times and decreases costs by eliminating the need for a hard pattern. Complex geometries enabled by AM-printed sand molds can reduce weight or improve designs for thermal dissipation. Furthermore, when AM tooling enables part consolidation of castings, the new cast part can have increased durability by eliminating welds or fasteners.

## Repair

AM is utilized for repairing metal aircraft engine parts such as turbine engine parts, blades, compressors, and housings. When a part is worn or broken, the part is normally scrapped and a new part manufactured; however, with AM, the lifetime of the part can be extended [45]. Parts are repaired by removing the damaged material area and reconstructing the part using the undamaged area [46]. The most common AM process for repair is directed energy deposition (DED). The value of AM repair is impacted by factors such as inspection for defects, the ability to repair the part in the field, the speed and cost of alternative repair techniques, and the requirement to restore the part to the original form with the same mechanical properties [47].

Laser Engineered Net Shaping (LENS) from Optomec successfully repaired parts used in gas turbine engines [45]. Repairing a bearing housing using LENS was only 50% of the cost of buying a new housing, with the lead time decreasing from several weeks to a few days [48]. One particularly dramatic example is BeAM, a European manufacturer of DED machines, which repaired over 800 aerospace parts and extended the life of the part from 10,000 to 60,000 hours [49].

When AM is used for core fabrication, material scrap can be reduced by 90% compared to traditional manufacturing.

## End-Usable Parts

Another application for aerospace and defense is the direct fabrication of end-usable parts. One of the most visible examples of metal AM parts for maintenance and sustainment has been the U.S. Naval Air Systems Command's (NAVAIR's) demonstration of a titanium link and fitting assembly for the engine's nacelle on the V-22 Osprey aircraft (shown in Figure 5). This part had to undergo extensive materials and performance testing for qualification and certification before being placed on the aircraft [50, 51].

A plastic material extrusion desktop 3D printer was used by the U.S. Marines on the USS Wasp to make a replacement plastic bumper for an F-35B landing gear door (see Figure 6). In the left photo of the figure, CW02 Daniel Rodriguez



Figure 6: (Top) CW02 Rodriguez Holding the Bumper and (Bottom) Sgt. Willis Demonstrating the 3D Printer (Source: U.S. Marine Corps Photos by Cpl. Stormy Mendez).

is holding the 3D printed plastic F-35B landing gear bumper for an F-35B Lightning II. On the right is Sgt. Adrian Willis demonstrating the 3D printer used to print the bumper part. This replacement part saved \$70,000 and several days, as the only way to replace the bumper without 3D printing would



Figure 5: Titanium Link and Fitting Assembly for the V-22 (Source: Noel Hepp, U.S. Navy).



have been to order and ship a complete door to the Wasp [52].

AM also enables complex designs where material is added only where needed to provide strength, stiffness, interface, or manufacturability requirements; the design freedom can lead to weight savings. One design team analyzed the benefits of AM for a commercial airplane seat buckle redesigned to save energy and weight. By redesigning for AM, the weight dropped from 155 g to 68 g. With 853 seats in an Airbus A380, the replacement design would recover a total of a 74 kg, resulting in a lifetime savings of 3,300,000 liters of fuel [53].

GE Aviation demonstrated the combined benefits of weight savings and part consolidation in the next-generation, additively-manufactured LEAP fuel nozzle. The nozzles were redesigned from a 20-part assembly to a single component, with a 25% weight reduction. Not only were the nozzles lighter, but more durable and 5x stronger than the original design [54–55]. GE plans to manufacture up to 100,000 parts with AM by 2020 [16].

AM is also revolutionizing manufacturing in space. The National Aeronautics and Space Administration (NASA) has identified AM for remote manufacturing for sustainment of long-duration missions and human exploration [56]. The Made In Space material extrusion printer was installed on the International Space Station (ISS) in November 2014, later followed in March 2016 by the installation of the more capable Additive Manufacturing Facility (AMF) at the ISS [57]. Another exciting application area of AM in space is the potential to print and deploy satellites in orbit, potentially providing a means of reconstituting satellite constellations degraded due to age, natural damage, or combat [58–59].

## QUALIFICATION AND CERTIFICATION

The aerospace industry uses qualification, certifications, and quality controls in order to ensure public safety. The qualification and certification process for aircraft components can cost over \$130 million and take up to 15 years, as shown in Figure 7 for a traditional Federal Aviation Administration (FAA) certification approach [32, 60]. Using AM for direct-part production presents a challenge for qualification and certification, especially for critical components [60]. The AM process is relatively new and, consequently, has few standards and minimal flight heritage. Therefore, many companies, organizations, and the government are encouraging the creation of standards [32, 61]. Studies have estimated for one given AM process, there are over a hundred variables that need to be controlled to produce stable and repeatable parts [62]. The lack of AM standards results in several barriers for AM implementation—material data are not comparable between companies, different process parameters are used by various AM machine operators, repeatability of results can be

insufficient, and few specifications exist to ensure a product is built as specified [8].

The FAA established the Additive Manufacturing National Team to collaborate with industry, academia, and government agencies in applying current FAA regulations to AM products and developing guidelines to certify structure safety. One of the first metal AM parts certified by the FAA was GE Aviation’s T25 sensor housing. GE designed, prototyped, produced, and certified this part in only 4 months and initiated a retrofit on 400 fielded engines [54].

In metal AM processes like powder bed fusion, unique material issues exist that impact qualification and certification. Mechanical properties are not uniform within a part. Inherent material anomalies could affect fracture toughness and fatigue (i.e., cyclic loading) strength, including lack of fusion, distributed porosity, inclusions, and residual stress [33]. For AM, an important step in process qualification is monitoring the AM process during part builds to identify process errors detrimental to the component. Research is ongoing to detect defects while a metal AM build is in progress [63].

Building Block Test Structure Required for Certification		Specimen Count	Cost (\$M)	Time (Yrs)
Analysis Validation	Full-Scale Article	2-3	100-125	4
	Components	10-30	10-20	3
Design-Value Development	Sub-components	25-50	10-35	3
	Elements	2,000-5,000	10-35	3
Material Property Evaluation	Coupons	5,000-100,000	8-15	2

Figure 7: The Traditional FAA Building Block Test Approach for Certification [60].

Collaboration is necessary to accelerate adopting AM and address qualification and certification issues. America Makes, a public-private partnership established by the federal government, has focused on addressing AM challenges through government, industry, and academia collaboration [64, 65]. In 2016, America Makes and American National Standards Institute (ANSI) formed the Additive Manufacturing Standardization Collaborative (AMSC) to bring together Standards Development Organizations such as American Society for Testing and Materials (ASTM) International, American Welding Society, Institute of Electrical and Electronics Engineers (IEEE), and the International Organization for Standardization (ISO). In February 2017, the first version of a standards roadmap was completed [66]. This roadmap listed existing standards and specifications for AM, identified AM-related standards in development, and outlined gaps where new standards are needed.

## CONCLUSION

AM is a suite of manufacturing processes that can reduce maintenance time and costs through prototyping, tooling, fixtures, jigs, part repair, and spare part production. Reductions in lead time, cost, and improved buy-to-fly ratio are realized today. If design changes are permitted, then complex geometric lightweight parts will enable energy-saving and positive environmental impact.

Challenges still need to be overcome to enable more widespread adoption of AM, including process control, geometric tolerances, quality assurance, and repeatability [67, 68]. Process control, known material properties, and confidence in repeatedly obtaining these properties are needed for certification authorities when dealing with flight-critical parts [24, 32]. AM designing

## AM will inevitably play a greater role in aerospace production, maintenance, and sustainment.

is another obstacle. Engineers taught design approaches for traditional manufacturing now need to adapt to leverage the design freedoms of AM [14, 45]. One study revealed barriers to adopting AM, including cost, lack of trained talent, uncertainty of quality of final product, and printer speed [69].

The needs for maintenance and sustainment are substantial, particularly for legacy fleets. The perceived benefits of AM outweigh the challenges. As a result, AM will inevitably play a greater role in aerospace production, maintenance, and sustainment. ■

## ACKNOWLEDGMENT

This effort was performed through the National Center for Defense Manufacturing and Machining under the America Makes Program titled “Maturation of Advanced Manufacturing for Low Cost Sustainment (MAMLS)” and is based on research sponsored by the U.S. Air Force Research Laboratory under agreement number FA8650-16-2-5700.

## REFERENCES

- [1] Merritt, Z. D. “Defense Inventory: Services Generally Have Reduced Excess Inventory, but Additional Actions Are Needed.” U.S. Government Accountability Office; report no. GAO 15-350, April 2015.
- [2] Sirichakwal, I., and B. Conner. “Implications of Additive Manufacturing for Spare Parts Inventory.” *3D Printing and Additive Manufacturing*, vol. 3, pp. 56–63, 2016.

- [3] Pickup, J. “Boeing Celebrates Delivery of 50<sup>th</sup> 747-8.” *Boeing MediaRoom*, <http://boeing.mediaroom.com/2013-05-29-Boeing-Celebrates-Delivery-of-50th-747-8>, accessed 29 May 2013.
- [4] Tinker AFB Public Affairs. “422<sup>nd</sup> SCMS Provides Key Support to the Warfighter – The Tinker Take Off.” <http://journalrecord.com/tinkertakeoff/2014/09/25/422nd-scms-provides-key-support-to-the-warfighter/>, 2014.
- [5] Seck, H. H. “Spare Parts Shortage Grounds Many Marine Corps Aircraft.” <https://www.military.com/daily-news/2017/02/10/spare-parts-shortage-grounds-most-marine-corps-aircraft.html>, accessed 28 December 2017.
- [6] Marchese, K., J. Crane, and C. Haley. “3D Opportunity for the Supply Chain: Additive Manufacturing Delivers.” <https://www2.deloitte.com/insights/us/en/focus/3d-opportunity/additive-manufacturing-3d-printing-supply-chain-transformation.html>, September 2015.
- [7] Conner, B. P., G. P. Manogharan, A. N. Martof, L. M. Rodomsky, C. M. Rodomsky, D. C. Jordan, et al. “Making Sense of 3-D Printing: Creating a Map of Additive Manufacturing Products and Services.” *Additive Manufacturing*, vol. 1–4, pp. 64–76, 2014.
- [8] Huang, Y., and M. C. Leu. “Frontiers of Additive Manufacturing Research and Education—Report of NSF Additive Manufacturing Workshop.” Center for Manufacturing Innovation, University of Florida, pp. 1–35, March 2014.
- [9] McCutcheon, R., R. Pethick, B. Bono, and M. Thut. “3D Printing and the New Shape of Industrial Manufacturing.” Price Waterhouse Coopers, 2014.
- [10] Brackett, D., I. Ashcroft, and R. Hague. “Topology Optimization for Additive Manufacturing.” *Proceedings of the Solid Freeform Fabrication Symposium*, Austin, TX, pp. 348–362, 2011.
- [11] Cheng, L., P. Zhang, E. Biyikli, J. Bai, J. Robbins, and A. To. “Efficient Design Optimization of Variable-Density Cellular Structures for Additive Manufacturing: Theory and Experimental Validation.” *Rapid Prototyping Journal*, vol. 23, pp. 660–677, 2017.
- [12] Huang, R., M. Riddle, D. Graziano, J. Warren, S. Das, S. Nimbalkar, et al. “Energy and Emissions Saving Potential of Additive Manufacturing: The Case of Lightweight Aircraft Components.” *J. Clean Prod.*, vol. 135, pp. 1559–1570, 2016.
- [13] Wohlers, T. “Wohlers Report 2018.” Wohlers Associates, Inc., 2018.
- [14] Kira. “U.S. Air Force to Integrate 3D Printing Into Almost All Aspects of Aircraft Design and Maintenance.” <http://www.3ders.org/articles/20151021-us-air-force-to-integrate-3d-printing-into-aircraft-design-and-maintenance.html>, accessed 13 January 2016.
- [15] Byron, A. J. “Qualification and Characterization of Metal Additive Manufacturing.” Massachusetts Institute of Technology. <http://dspace.mit.edu/handle/1721.1/104315>, 2016.
- [16] Markets, S. “Additive Manufacturing in Aerospace: Strategic Implications.” White paper, <http://www.smartechpublishing.com>, 2014.
- [17] Benedict. “GE Moves Forward With Takeover of 3D Printing Companies Arcam AB, Concept Laser.” <http://www.3ders.org/articles/20161214-ge-moves-forward-with-takeover-of-3d-printing-companies-arcam-ab-concept-laser.html>, accessed 21 February 2017.
- [18] ISO/ASTM 52900-15. “Standard Terminology for Additive Manufacturing – General Principles – Terminology.” ASTM International, West Conshohocken, PA, 2015.
- [19] Bihlman, B. “Aerospace Materials and Design.” *Aerospace Manufacturing and Design*, <http://www.aerospacemanufacturinganddesign.com/article/amd1015-aerospace-materials-design-outlook/>, accessed 23 March 2017.
- [20] Dehoff, R., C. Duty, W. Peter, Y. Yamamoto, C. Wei, C. Blue, et al. “Case Study: Additive Manufacturing of Aerospace Brackets.” *Adv. Mater. Processes*, vol. 171, pp. 19–22, 2013.
- [21] Campbell, T., C. Williams, O. Ivanova, and B. Garrett. “Could 3D Printing Change the World?” *Technologies, Potential, and Implications of Additive Manufacturing*, Atlantic Council, Washington, DC, <http://www.cbpp.uaa.alaska.edu/afef/Additive%20MFG%20.pdf>, 2011.

- [22] Gibson, I., D. Rosen, and B. Stucker. *Additive Manufacturing Technologies: 3D Printing, Rapid Prototyping, and Direct Digital Manufacturing*. Springer, 2014.
- [23] Thomas, D. S., and S. W. Gilbert. "Costs and Cost Effectiveness of Additive Manufacturing." National Institute of Standards and Technology, December 2014.
- [24] Guo, N., and M. C. Leu. "Additive Manufacturing: Technology, Applications and Research Needs." *Front Mech. Eng. Chin.*, Springer Berlin Heidelberg, vol. 8, pp. 215–243, 2013.
- [25] Perez, M., M. Block, D. Espalin, R. Winker, T. Hoppe, F. Medina, et al. "Sterilization of FDM-Manufactured Parts." Proceedings of the 2012 Annual International Solid Freeform Fabrication Symposium, Austin, TX, pp. 6–8, August 2012.
- [26] Greenwood, D., and R. Francis. Fleet Readiness Centers. NAVAIR Additive Manufacturing Industry Day, <http://www.navair.navy.mil/osbp/index.cfm?fuseaction=home.download&id=596>, 24 July 2014.
- [27] Lyons, B. "Additive Manufacturing in Aerospace: Examples and Research Outlook." *Bridge*, vol. 44, <https://trid.trb.org/view.aspx?id=1328197>, 2014.
- [28] Gonzalez, P. A. "High Temperature Laser Sintering Technologies for Air and Space Vehicles." *Euro mold 2015*, Dusseldorf, Germany, 25 September 2015.
- [29] Love, L. J., V. Kunc, O. Rios, C. E. Duty, A. M. Elliott, B. K. Post, et al. "The Importance of Carbon Fiber to Polymer Additive Manufacturing." *J. Mater. Res.*, Cambridge University Press, vol. 29, pp. 1893–1898, 2014.
- [30] Goehrke, S. A. "Markforged Expands Industrial 3D Printer Line: CEO Details Accessibility in Local Manufacturing." <https://3dprint.com/184188/markforged-industrial-x-line/>, accessed 21 August 2017.
- [31] Goehrke, S. A. "Impossible Objects Presents Model One 3D Printer, Tells Us Their Composite-Based Additive Manufacturing Will Compete With Injection Molding." <https://3dprint.com/173381/impossible-objects-model-one/>, accessed 21 August 2017.
- [32] Frazier, W. E. "Metal Additive Manufacturing: A Review." *J. Mater. Eng. Perform*, Springer, vol. 23, pp. 1917–1928, 2014.
- [33] Seifi, M., M. Gorelik, J. Waller, N. Hrabec, N. Shamsaei, S. Daniewicz, et al. "Progress Towards Metal Additive Manufacturing Standardization to Support Qualification and Certification." *JOM*, Springer, vol. 69, pp. 439–455, 2017.
- [34] Lewandowski, J. J., and M. Seifi. "Metal Additive Manufacturing: A Review of Mechanical Properties." *Annu. Rev. Mater. Res.*, vol. 46, pp. 151–186, 2016.
- [35] 3D-Printing Milestone. "Puris 3D Prints Largest Titanium Part." <http://www.businesswire.com/news/home/20160120006401/en/3D-Printing-Milestone-Puris-3D-Prints-Largest-Titanium>, accessed 3 April 2017.
- [36] Khajavi, S. H., J. Partanen, and J. Holmström. "Additive Manufacturing in the Spare Parts Supply Chain." *Comput. Ind.*, vol. 65, pp. 50–63, 2014.
- [37] Myers, M. "3-D Printers Save Time, Money in Major Aircraft Repairs." *Navy Times*, <https://www.navytimes.com/story/military/tech/2015/03/21/navy-aircraft-3d-printing-repairs-fa-18/24959201/>, accessed 3 April 2017.
- [38] Hiemenz, J. "Additive Manufacturing Trends in Aerospace." White paper, Stratasys, pp. 1–11, 2014.
- [39] Taylor, S. "Stratasys & Whale Create 97% Lead Time Reduction With 3D Printing." 3D Printing Industry, <https://3dprintingindustry.com/news/stratasys-whale-create-97-lead-time-reduction-3d-printing-28060/>, accessed 11 April 2017.
- [40] Stratasys. "Additive Manufacturing Reduces Tooling Cost and Lead Time to Produce Composite Aerospace Parts." <http://www.stratasys.com/resources/case-studies/aerospace/acs>, 2015.
- [41] Shoemaker, S., and J. Bernales. "3D Printed Tool for Building Aircraft Achieves Guinness World Records, Oak Ridge National Laboratory." <https://www.ornl.gov/news/3d-printed-tool-building-aircraft-achieves-guinness-world-records-title>, accessed 21 August 2017.
- [42] Scheck, C. E., J. N. Wolk, W. E. Frazier, B. T. Mahoney, K. Morris, R. Kestler, et al. "Naval Additive Manufacturing: Improving Rapid Response to the Warfighter." *Nav. Eng. J.*, vol. 128, pp. 71–75, 2016.
- [43] Dordlova, C., A. Lindwall, and P. Törlind. "Opportunities and Challenges for Additive Manufacturing in Space Applications." DS 85-1: Proceedings of NordDesign 2016, Trondheim, Norway, vol. 1, [https://www.designsociety.org/publication/39317/opportunities\\_and\\_challenges\\_for\\_additive\\_manufacturing\\_in\\_space\\_applications](https://www.designsociety.org/publication/39317/opportunities_and_challenges_for_additive_manufacturing_in_space_applications), 10–12 August 2016.
- [44] Cotteleer, M., M. Neier, and J. Crane. 3D Opportunity for Tooling: *Additive Manufacturing Shapes the Future*. Deloitte University Press, April 2014.
- [45] Guo, N., and M. C. Leu. "Additive Manufacturing: Technology, Applications and Research Needs." *Front. Mech. Eng. Chin.*, vol. 8, pp. 215–243, 2013.
- [46] Portolés, L., O. Jordá, L. Jordá, A. Uriondo, M. Esperon-Miguez, and S. Perinpanayagam. "A Qualification Procedure to Manufacture and Repair Aerospace Parts With Electron Beam Melting." *Journal of Manufacturing Systems*, vol. 41, pp. 65–75, 2016.
- [47] Kobryn, P. A., N. R. Ontko, L. P. Perkins, and J. S. Tiley. "Additive Manufacturing of Aerospace Alloys for Aircraft Structures." DTIC document, <http://oai.dtic.mil/oai/oai?verb=getRecord&metadataPrefix=html&identifier=ADA521726>, 2006.
- [48] Mudge, R. P., and N. R. Wald. "Laser Engineered Net Shaping Advances Additive Manufacturing and Repair." *Welding Journal-New York*, [http://www.rpm-innovations.com/laser\\_deposition\\_technology\\_advances\\_additive\\_manufacturing\\_and\\_repair](http://www.rpm-innovations.com/laser_deposition_technology_advances_additive_manufacturing_and_repair), 2007.
- [49] Charron, K. "BeAM Repairs More Than 800 Aerospace Parts With Industrial Metal 3D Printers." <https://www.3ders.org/articles/20160204-beam-repairs-more-than-800-aerospace-parts-with-industrial-metal-3d-printers.html>, accessed 26 December 2017.
- [50] NAVAIR Public Affairs Office. "NAVAIR Marks First Flight With 3-D Printed, Safety Critical Parts." <http://www.navair.navy.mil/index.cfm?fuseaction=home.printnewsstory&id=6323>, 2016.
- [51] Freedberg, S. J., Jr. "First Osprey Flight With Critical 3D Printed Part." *Breaking Defense*, <http://breakingdefense.com/2016/08/osprey-takes-flight-with-3d-printed-part/>, accessed 18 April 2017.
- [52] Mendez, S. "Marines Use 3-D Printer to Make Replacement Part for F-35 Fighter." *U.S. Department of Defense News*, <https://dod.defense.gov/News/Article/Article/1498121/marines-use-3-d-printer-to-make-replacement-part-for-f-35-fighter/>, accessed 30 September 2018.
- [53] 3T R. "SAVING Project – Saving Litres of Aviation Fuel." 3TRP, <https://www.3trpd.co.uk/portfolio/saving-project-saving-litres-of-aviation-fuel/>, accessed 4 October 2016.
- [54] Kellner, T. "The FAA Cleared the First 3D Printed Part to Fly in a Commercial Jet Engine From GE." GE Reports, <http://www.gereports.com/post/116402870270/the-faa-cleared-the-first-3d-printed-part-to-fly/>, accessed 25 January 2016.
- [55] Ford, S., and M. Despeisse. "Additive Manufacturing and Sustainability: An Exploratory Study of the Advantages and Challenges." *J. Clean Prod.*, vol. 137, pp. 1573–1587, 2016.
- [56] NASA. "Additive Manufacturing: Pioneering Affordable Aerospace Manufacturing." [https://www.nasa.gov/sites/default/files/atoms/files/additive\\_mfg.pdf](https://www.nasa.gov/sites/default/files/atoms/files/additive_mfg.pdf), 2016.
- [57] AMF. "Made in Space." <http://www.madeinspace.us/projects/amf/>, accessed 21 February 2017.
- [58] Kwas, A., E. MacDonald, C. J. Kief, R. Wicker, C. Soto, L. Bañuelos, et al. "Printing Multi-Functionality: Additive Manufacturing for CubeSats." AIAA Space 2014 Conference and Exposition, 2014.
- [59] Lyke, J. C. "Plug-and-Play Satellites." *IEEE Spectrum*, vol. 49, pp. 36–42, 2012.
- [60] Mies, D., W. Marsden, and S. Warde. "Overview of Additive Manufacturing Informatics: A Digital Thread." *Integrating Materials and Manufacturing Innovation*, vol. 5, December 2016.
- [61] Merissa, P., CSU, and S. Alexander. "Additive Manufacturing: A Summary of the Literature." [http://engagedscholarship.csuohio.edu/urban\\_facpub/1319/](http://engagedscholarship.csuohio.edu/urban_facpub/1319/), 2015.
- [62] Kabbara, J. "Additive Manufacturing [Internet]." Gorham PMA and DER Conference 2015; San Diego, CA, [http://gorham-tech.com/yahoo\\_site\\_admin/assets/docs/FAA\\_Additive\\_Manufacturing\\_Presentation.83150029.pdf](http://gorham-tech.com/yahoo_site_admin/assets/docs/FAA_Additive_Manufacturing_Presentation.83150029.pdf), 24 March 2015.
- [63] Nassar, A. R., T. J. Spurgeon, and E. W. Reutzel. "Sensing Defects During Directed-Energy Additive Manufacturing of Metal Parts Using Optical Emissions Spectroscopy." Solid Freeform Fabrication Symposium Proceedings, University of Texas, Austin, TX, <http://sffsymposium.engr.utexas.edu/sites/default/files/2014-024-Nassar.pdf>, 2014.
- [64] Swenson, G. "National Additive Manufacturing Innovation Institute Announced." *NIST*, <https://www.nist.gov/news-events/news/2012/08/national-additive-manufacturing-innovation-institute-announced>, accessed 29 December 2017.
- [65] Good, A. "About – America Makes." <https://www.americamakes.us/about/>, accessed 29 December 2017.
- [66] America Makes and ANSI AMSC. "Standardization Roadmap for Additive Manufacturing." ANSI/National Center for Defense Manufacturing and Machining, [https://www.ansi.org/standards\\_activities/standards\\_boards\\_panels/amsc/Default?menuid=3](https://www.ansi.org/standards_activities/standards_boards_panels/amsc/Default?menuid=3), February 2017.
- [67] Cotteleer, M., S. Trouton, and E. Dobner. "3D Opportunity and the Digital Thread." DU Press, <https://dupress.deloitte.com/dup-us-en/focus/3d-opportunity/3d-printing-digital-thread-in-manufacturing.html>, accessed 30 December 2016.
- [68] U.S. Department of Energy. "Additive Manufacturing: Pursuing the Promise." [https://energy.gov/sites/prod/files/2013/12/f5/additive\\_manufacturing.pdf](https://energy.gov/sites/prod/files/2013/12/f5/additive_manufacturing.pdf), 2012.
- [69] PricewaterhouseCoopers. "3D Printing Comes of Age in U.S. Industrial Manufacturing." <http://www.pwc.com/us/en/industrial-products/publications/assets/pwc-next-manufacturing-3d-printing-comes-of-age.pdf>, 2016.

## BIOGRAPHIES

**ASHLEY TOTIN** is a project engineer for America Makes, the National Additive Manufacturing Innovation Institute. Prior to joining America Makes, she was the Engineering Project Manager for the Youngstown Business Incubator, where her research interests included cost modeling and business case analysis pertaining to additive manufacturing. Mrs. Totin holds bachelor's and master's degrees in industrial and systems engineering from Youngstown State University, with a minor in mathematics.

**ERIC MACDONALD** is a professor of electrical and computer engineering and the Friedman Chair for Manufacturing at Youngstown State University. He worked in industry for 12 years at IBM and Motorola and subsequently cofounded a startup company where he developed computer-aided design software. From 2003 to 2016, he was the Associate Director of the W. M. Keck Center for 3D Innovation at the University of Texas, El Paso. He held faculty fellowships at NASA's Jet Propulsion Laboratory and the Space and Naval Warfare Systems Command (San Diego) and a State Department Fulbright Fellowship in South America. He has over 50 refereed publications and patents. Dr. MacDonald holds a Ph.D. in electrical engineering from the University of Texas at Austin.

**BRETT CONNER** is the Director of the Advanced Manufacturing Research Center and an associate professor of manufacturing engineering at Youngstown State University (YSU). Prior to joining the faculty at YSU, he was a U.S. Air Force officer, a defense contractor, and a research and development metallurgist at Alcoa. He is also the Chief Technology Officer and cofounder of Freshmade 3D, a company providing design services and advanced additive manufacturing materials solutions. Dr. Conner holds a bachelor's degree in physics from the University of Missouri and master's and doctorate degrees in materials science and engineering from MIT.



# MICRODIODE LASERS

## A SAFER ALTERNATIVE FOR ELECTRICALLY-FIRED ENERGETIC DEVICES

---

By Gregory Burke and John Hirlinger

---

### INTRODUCTION

**T**he world has seen a spiraling increase in electromagnetic devices that enhance communications capabilities and place a plethora of information at any user's fingertips. We are surrounded by electromagnetic emitters in virtually every location on the

planet—from a handheld cell phone to a Global Positioning System transceiver or radio broadcast. What most people take for granted is that there are energetic-containing devices present in these environments that must function reliably when directed but not function at any other time. A prime example of this is the airbag in most modern automobiles, a lifesaver when summoned to function. However, the airbag must remain sedentary when exposed to all the electromagnetic

radiation from the expected devices present in the automobile. Many hundreds, if not thousands, of development hours were expended to ensure that these conditions were satisfied before the first airbag was introduced.

This explosion of information capabilities has not been overlooked by most of the world's military organizations. Many of these electromagnetic devices have been modified and adapted by

the various militaries of the world to enhance communications, situational awareness, and target detection and perform as weapon systems, such as signal jammers and countermeasures devices. Smaller, more powerful emitting devices are fielded on military systems to enhance their offensive and defensive capabilities. Devices containing energetics must be certified as safe when operated near emitters.

The two primary methods of initiating energetic devices currently used in most systems are percussion (mechanical strike) or electrical. The main drawback to percussion initiation is that a mechanism storing an adequate amount of striking energy has to be present. The most utilized method for this is a compressed spring pushing a firing pin forward after releasing a firing retention device. The energetic device initiates when struck by the firing pin. A typical firing sequence diagram using percussion initiation is shown in Figure 1. Percussion initiation is usually a reliable mechanism, but the system pays a penalty in weight, volume, and number of moving parts associated with the striking mechanism.

Modern electrically-initiated devices function via either thermal ignition (resistive heating) using an electrically-conductive material placed in intimate contact with an energetic material or exploding foils. Instead of the mechanical striking energy utilized as the initiation energy in the percussion-initiated devices, an electrical power source must be present in the system to provide the initiation energy for the electrically-initiated devices. A typical firing sequence using electrical ignition is shown in Figure 2. Electrically-initiated devices can be found in many different applications from automobile airbags to cartridge-activated devices, gun primers, detonators, and fuzes.

The main drawback to percussion initiation is that a mechanism storing an adequate amount of striking energy has to be present.

Although electrically-initiated devices are predominant and mature, they suffer from two major drawbacks. First, based upon their functional requirements, these energetic compounds are sensitive to electrostatic discharge (ESD), which presents a safety concern for workers handling the lead-based energetics. They may be vulnerable to accidental initiation due to electronic warfare (EW) attack, including a susceptibility to ESD and other electromagnetic environmental effects. Secondly, as

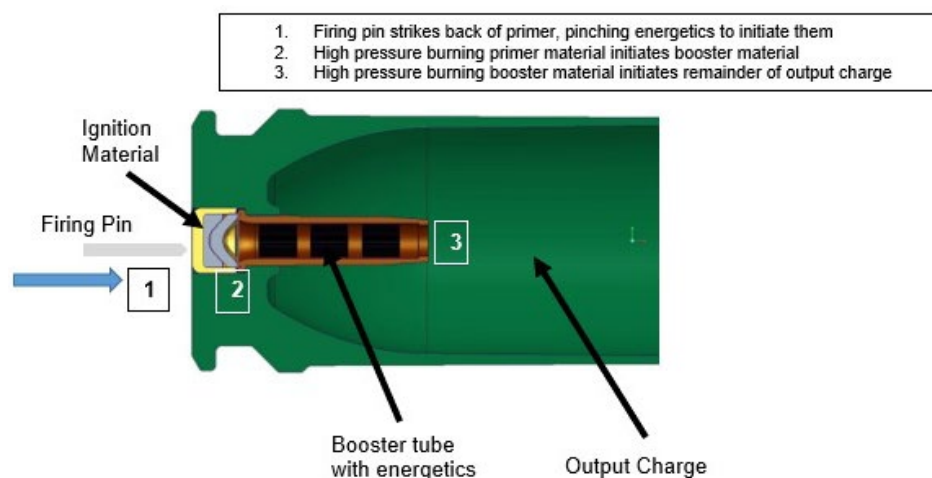

Figure 1: Typical Percussion Firing Sequence (Source: J. Hirlinger).

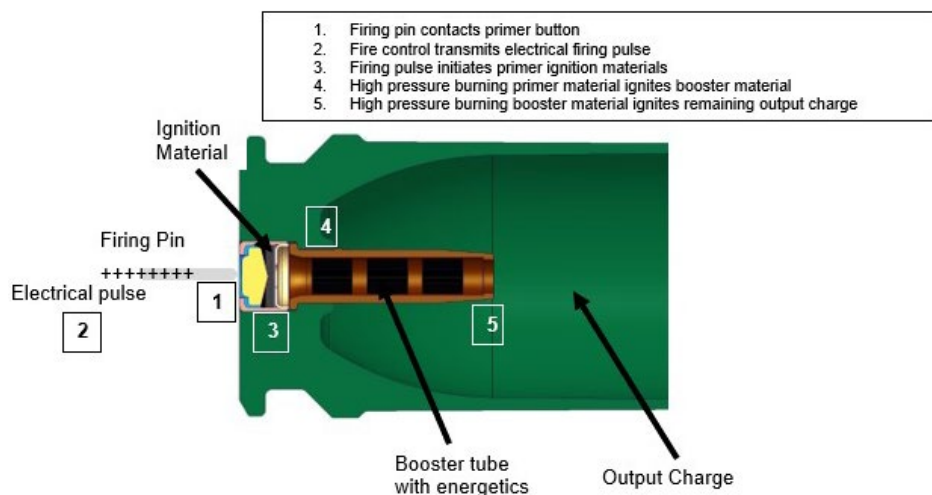

Figure 2: Typical Electrical Firing Sequence (Source: J. Hirlinger).

with the percussion-initiated devices, the energetic compounds used for initiation are predominantly lead-based materials, which are considered environmentally hazardous. To minimize the environmental impacts of these hazardous materials, some international organizations enacted regulations limiting the use of environmentally hazardous compounds. For example, the European Union (EU) established a broad regulation known as Registration, Evaluation, Authorization and Restriction of Chemicals (REACH) to govern producing and using many chemical compounds. Lead has been listed in the REACH regulation as “a substance of very high concern (SVHC)” in the EU. Additionally, U.S. Department of Defense Warfighter training grounds are increasingly becoming contaminated with lead-based residues from the combustion of these devices.

## WHAT IS MICRODIODE LASER IGNITION?

A microdiode laser converts an electrically-initiated device into an electro-optical one. Ignition is initiated via the same electrical input signal, but an optical output signal serves as the initiation mechanism. A microdiode laser ignition device makes three significant changes compared to most standard electrical initiators. First, the conductive element is replaced with an electrical device that creates an optical output—in this case, a microdiode laser. Secondly, the initiation energetics are removed from intimate contact with the conductive device and placed behind an optically-transparent barrier. Third, the microdiode laser igniters function adequately with nonlead-containing energetics.

A typical firing sequence using microdiode laser ignition is shown in Figure 3. The U.S. Army Combat Capabilities Development Command

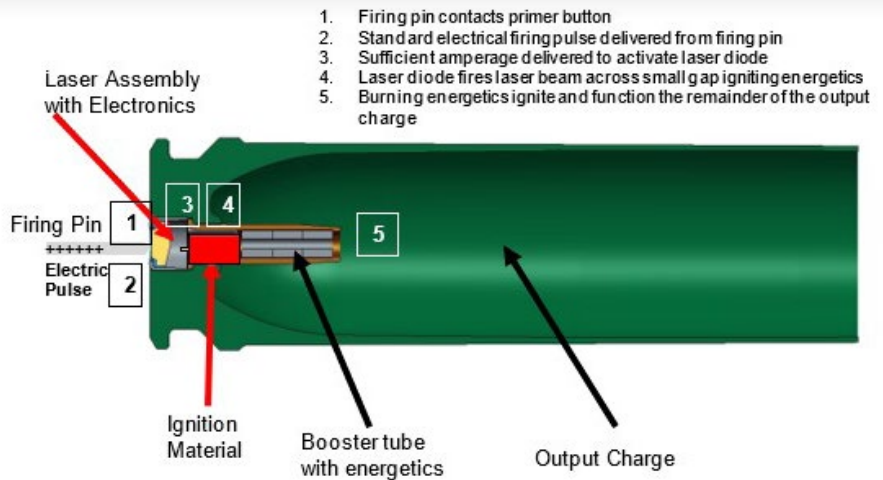

Figure 3: Typical Microdiode Laser Ignition Sequence (Source: J. Hirlinger).

(CCDC) Armaments Center is evaluating the application of these solid-state, microdiode laser devices as alternative ignition devices to traditional electrically-initiated devices. Microdiode laser initiation may offer novel solutions to many of the aforementioned technical concerns, such as reducing the use of lead-based energetics, improving resistance to evolving EW threats, reducing or eliminating mechanical moving parts during the initiation sequence, and directing “speed of light” interfacing with ignition/firing control systems.

Today, microdiode laser technology is ever present in our modern world of electronics. It exists in digital versatile disc players, smart phones, and low-cost laser pointers and has become a low-cost, commodity item. Microlaser diodes are incredibly small, solid-state devices that, when subjected to the proper electrical stimulus, output optical signals. Figure 4 shows a typical microlaser chip compared to a U.S. dime. The CCDC Armaments Center is interested in using simple, very low-power microlaser diodes and, in some cases, those nearly as small as the head of a pin. These devices, while separated by a translucent environmental barrier,

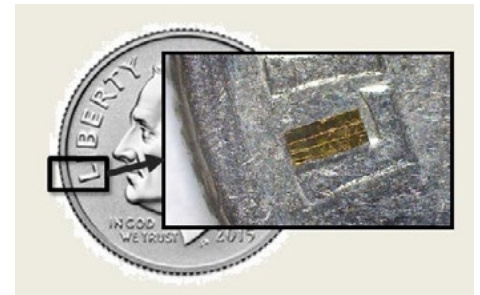

Figure 4: Microlaser Diode on a Dime (Source: S. Redington).

are now physically separated from but still in close proximity (< 0.5 mm) to the energetic initiation compound. Strategically placing the laser diodes near the energetics eliminates the need for additional focusing optics to ensure ignition. This approach is best suited to one-time use, single function devices such as primers, fuze detonators, and other quick-functioning, gas-generating devices.

## MICRODIODE LASER VS. OTHER LASER IGNITION DEVICES

Laser ignition has been used since the 1960s. For example, a Crusader (Figure 5, top) was modified and fired over 25,000 rounds using laser ignition, and an LW155 (Figure 5, bottom) was



Figure 5: Two Artillery Systems Modified for Laser Ignition: The Crusader (Top) and LW155 (bottom) (Source: G. Burke).

modified and fired over 5,000 rounds. Current laser-ignited devices utilize a remote, centrally-located, high-powered laser connected to the ignition source via a light conductive cable (i.e., a fiber optics cable). The laser is pulsed and the light transmitted through the fiber optics cable through a connecting surface, which may or may not have a focusing lens, into the initiating energetics. Microlaser ignition takes advantage of the significantly smaller size of the microdiode and places the laser source in the end item, eliminating the fiber optics cable and any focusing systems.

The demands of the consumer market for smaller yet more powerful devices, from entertainment to medical, have paved the way for developing a wide variety of microlasers. Commercially-available, solid-state microlasers offer many options, including size, output power, power consumption, footprint, and wavelength. Based upon the requirements and environments of their systems, solid-state diode microlasers were developed to have long, functional lifetimes of 10,000 hours. As a result, the life expectancy for a single-use ignition device is essentially forever. As the laser device is fabricated on a silicon substrate, the base material is inert,

with a very low expansion coefficient. As an example, consider the microlaser within the compact disc (CD) player of an automobile. The device sits inside the dashboard in the hot sun and freezing cold and vibrates and bounces around for many miles. Despite all of these environmental changes, the laser diode is probably the least likely of the electrical components to fail in the CD player. Microlaser devices in their current applications have already proven themselves to be comparatively low cost and quite reliable, as well as durable.

The life expectancy  
for a single-use ignition  
device is essentially  
forever.

Miniaturizing the laser source based upon commercial usage brings the cost and availability of these devices down to a level that makes it practical for them to be considered as single-use, “throw-away” devices. Figure 6 shows an example of a finished, sealed, single-use microdiode laser electronic assembly developed for an ammunition application. The almost limitless variety of these devices introduces a wide host of novel energetic materials for investigators to explore not only in



Figure 6: A Sealed, Self-Contained Microdiode Laser Ignitor (Source: S. Redington).

thermal ignition methodologies, but potentially in optochemical reactions as well. As with all commodities, the cost of the microlaser is volume driven. The greater number of laser diode applications using common energetics and other components increases the demand volume, thereby decreasing individual costs.

## ADVANTAGES OVER STANDARD ELECTRICAL IGNITORS

The ability to physically isolate the energetic from the ignition source, in this case, the microlaser element, results in a unique and value-added benefit of this technology. The energetic can now be encapsulated into a laser-transparent hermetic package. This translates to a significant increase in safety of the ignitor device as it is not vulnerable to initiation by heating caused from a prolonged, low electrical current. Instead, the laser must receive the designed electrical input to pulse the laser before ignition. Lower input may cause the diode to “glow” similar to a light-emitting diode (LED). But until the threshold energy value is achieved, the diode will not function as a laser and emit the level of concentrated photons required for ignition. CCDC Armaments Center engineers have demonstrated the ability to miniaturize, seal, and environmentally package the energetic source, thus ensuring a predictable, isolated separation between energetic and laser sources governed by a laser transparent barrier. The automated robotic and compartmentalized handling of energetics eliminates the current method of physical processing by workers and inherent risks.

The unique feature of independent laser and energetic assemblies enables another advantage for this technology—the microlaser and electronic components can be manufactured

by multiple, nontraditional defense contractors. The parts can be fabricated independent of the end-item application and functionally tested at multiple points within the fabrication and assembly process. The major advantage to this technique over standard electrical ignitors is that it now allows full, functional verification of the ignition source as the end-item assembly process progresses. A full, functional test of a standard electrical ignitor usually results in consuming the ignitor, thus rendering it unusable for end item application. This opens the door to multiple, competitively-based sources of supply and greater assurance of functionality at the end-item application level. Only during the final assembly stage, within the facilities of a qualified integrator of energetics-based hardware, is the microlaser electronic subassembly mated with the energetic subassembly. This approach departs radically from traditional methods for some electrical ignitors where the energetic and electronic components are mated from the very onset of fabrication. Relative to the actual fabrication process, a variety of methods can handle and process microlaser, diode-based electronic assemblies.

This technology embraces modern electronics assembly techniques such as surface mount technology (SMT). Traditionally, wire-bonding procedures are the most common way to mount a laser diode to the supporting structure in commercial applications. Refined over many years, this process is considered a mature and reliable method. Unfortunately, wire-bonding techniques may not be sufficiently robust when applied to energetics-based applications. As a result, CCDC Armaments Center developed several novel processes more suited toward military-hardened, laser-based initiation hardware.

Microlaser devices in their current applications have already proven themselves to be comparatively low cost and quite reliable, as well as durable.

Figure 7 shows an SMT in process electronics assembly board with 20 microdiode electronics subassemblies prior to final removal and packaging. To address these enhanced design requirements, CCDC Armaments Center's goal with microlaser assemblies has been to move toward SMT processes using "tape and reel," "pick and place," and robotic automated assembly processes. SMT can provide a combination of microelectronics and micro-optics, providing novel hybrid "smart" initiation devices. SMT techniques can provide high reliability, precise robotic component placement, high yield, rapid assembly, lower costs, and the ability to move toward additive

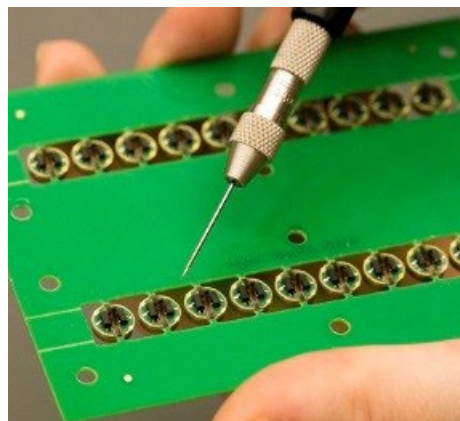

Figure 7: Surface Mounting Electronics and Laser Diodes (Source: S. Redington).

and flexible manufacturing techniques. Further, multiple microlaser diodes can incorporate into a single-ignitor assembly scheme, allowing redundancy to achieve greater reliability if one or more laser devices fail. The technology also allows expanding to multipoint simultaneous or sequential ignition, with the goal of delivering efficient, more-versatile, higher-output propulsion systems.

For future design applications where the firing circuit is yet to be specified, microlaser ignition via SMT manufacturing technology provides the potential integration of a host of smart features, such as a bidirectional communication link, chip identification (electronic handshake) or other user identification, temperature sensing, age, lot, and other features. All or some of these features can be added to the design as required. One of the design goals for future military systems is higher precision. Electrical ignition utilizing microlaser ignition can eliminate most of the time interval required to mechanically move components to create the required kinetic energy for ignition and the physical vibration associated with the movement and impact of these moving parts within the firing system. This leads the way toward computer-controlled/automated firing systems that allow improved coincidence based on computational analysis of range, wind, temperature, and mechanical motion of the weapon platform.

## MOVING FORWARD

We need to first change how we think about our electromagnetic environment that is rapidly saturated by more and more emitting devices. In the world of explosive devices, safety is paramount. Operational workarounds are no longer practical due to the proliferation of



emitting devices. We need to develop and produce fully-resistant devices that can withstand the emission of these emitters. Second, we need to overcome the reluctance to accept new technologies, especially when it comes to perturbing the long established production facilities making reasonably priced hardware. Photographic film vs. digital imagery, hard-wired telephones vs. cell phones, and cathode ray tube-based TV vs. LED/liquid crystal display flat panel TV sets are just a few historical examples of initial resistance to change that have occurred over the past 20 years (often based upon the price differential of new technology vs. existing products). Continuing to produce the same products based upon decades-old electrical ignition designs ignores the changing world around us and will eventually lead to devices that cannot be removed from their shipping containers for fear of accidental initiation from the electromagnetic environment. Lastly, there is a need to recognize that the ignitor community must move on to newer, nonlead-based compounds to serve as the ignition material. Our training grounds are fast becoming contaminated with lead-based residues as well as the work areas in the assembly facilities where workers are exposed to lead-based products daily. Microlaser-based ignition devices offer a wider variety of new and old pyrotechnic chemical products to use as substitutes for lead-based energetics.

Current experimentation in a variety of applications has shown comparable, functional results between microdiode laser ignitors and traditional electrical ignitors utilizing the firing pulse of the existing system. This means that changing over to a microdiode laser system can be accomplished without any costly changes to the current system. Will microdiode lasers completely

replace all current and future electrical ignition devices? Probably not. But the encouraging results obtained so far and exploring this and other novel ignition techniques will certainly move us toward safer, more-reliable initiation devices. ■

## BIOGRAPHIES

**GREGORY BURKE** is a subject matter expert at the CCDC Armaments Center, Picatinny Arsenal, NJ, specializing in high-power laser systems for use in directed energy, ignition of energetics, and biomedical technologies. He holds multiple patents in laser technology, optical microwave-based medical diagnostics, and other applications merging optics, electronics, and mechanical systems. Mr. Burke supports the Army through research and development, system demonstration, and pre-production manufacturing concepts. His current research effort is in microlaser miniaturization as a HERO safe alternative primer for the M230, 30-mm cartridge ammunition and novel ignition alternatives, such as a radio frequency (microwave) ignition for future artillery systems.

**JOHN HIRLINGER** is the Technical Executive for Medium Cannon Caliber Ammunition at the CCDC Armaments Center, Picatinny Arsenal, NJ. As the engineering manager for all Army aviation medium cannon caliber ammunition projects, he has over 41 years of experience in the field and worked on multiple nonrecurring engineering, research, development, test and evaluation and production-related projects in medium cannon caliber ammunition. As the project lead for the Sub-Miniature Laser Igniters project, he is responsible for developing and integrating a laser ignition system fully mounted within the munition as a substitute for the standard electrical primers. Mr. Hirlinger holds a bachelor's degree in aeronautical engineering from Pennsylvania State University.

## DSIAC FEATURED EXPERT *John Tatum*



DSIAC would like to take a moment to recognize a subject matter expert who has provided users with valuable help and assistance.

**JOHN TATUM** is an electronic systems engineer with the SURVICE Engineering Company, working in electronic warfare (EW) and radio frequency (RF) directed energy weapons. Prior to joining SURVICE, he worked for more than 36 years at the U.S. Army Research Laboratory's RF Electronics Division in radar/EW, where he directed and participated in electromagnetic/RF effects investigations on military systems and supporting infrastructure.

**Years of experience:** 40 years

**Expertise:** directed energy

**Number of DSIAC publications:** 4

**Learn more about John Tatum:**

[https://www.dsiac.org/resources/presenters\\_authors/john-tatum](https://www.dsiac.org/resources/presenters_authors/john-tatum) ►

# A Titanium-Based Igniter System for HAND-GRENADE FUZZES

By Anthony P. Shaw, Jay C. Poret, Lori J. Groven, Joshua T. Koenig, and Jason S. Brusnahan

## SUMMARY

**T**he A-1A and titanium/potassium perchlorate (TPP) igniter compositions have been used in hand grenade fuzes for many years. However, producing or sourcing acceptable-quality

A-1A has been challenging. TPP contains potassium perchlorate, which has been targeted for removal from pyrotechnics by the U.S. Department of Defense. In hand-grenade fuzes, an input charge is often used to ignite the delay composition. After a period of time, the delay composition typically ignites an output charge, causing hot gases, incandescent combustion products, and ejected titanium sparks. Conventional pyrotechnics requires a nearly-gasless input charge (A-1A) and an



(Photo Source: U.S. Army)

explosive output charge (TPP). A ternary mixture of titanium, manganese dioxide, and polytetrafluoroethylene (PTFE) can fulfill both purposes. The PTFE serves as a gas generator, lubricant, and dry binder. Pressed layers of the new titanium based igniter possess adequate mechanical strength and effectively retain delay increments that do not contain any binder. Importantly, as an input charge, the new igniter does not prematurely rupture fuze cases or eject percussion primers. Yet, as an output charge, it produces a brilliant burst of sparks similar to TPP.

## INTRODUCTION

In munitions, pyrotechnic delay elements are used to time sequences of energetic events. For example, fuzes for hand grenades must provide a reliable and safe interval between when the primer is struck (the grenade is released) and subsequent initiation of the main charge. The M201A1 fuze, fitted on U.S. Army smoke grenades, contains a pyrotechnic delay element that burns for ~1.0–2.3 s. The M213 and M228 fuzes are used in the M67 and M69 fragmentation and practice grenades, respectively. These munitions require a 4.0–5.5-s delay time. The M208 fuze provides an 8–12-s delay time and is used in smoke pots, which are large canisters filled with smoke-producing pyrotechnic compositions. Other specialized pyrotechnic delay elements in munitions provide delay times of 15–20 s or longer, depending on functional requirements. A generalized configuration is shown in Figure 1. In hand-grenade fuzes, the initiator is typically a percussion primer.

The pyrotechnic delay formulations typically used in hand grenade fuzes use objectionable chemicals such as barium chromate, lead chromate, and potassium perchlorate. In this context, the nearly-gasless Mn/MnO<sub>2</sub> and W/

The Ti/MnO<sub>2</sub>/PTFE composition produces enough gas as an output charge to forcefully eject incandescent molten oxides and titanium sparks.

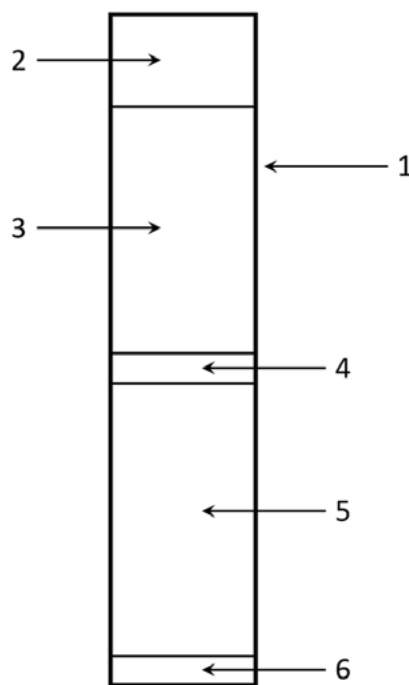

Figure 1: Cross-Sectional Representation of an Exemplary Pyrotechnic Delay Element: (1) Case, (2) Initiator, (3) Headspace, (4) Igniter Composition (Input Charge), (5) Delay Composition, and (6) Another Igniter Composition (Output Charge) (Source: U.S. Army Combat Capabilities Development Command [CCDC] Armaments Center).

MnO<sub>2</sub> thermitic systems have been explored as possible replacements [1, 2]. However, there are other problematic components in such fuzes. As an example, within the M201A1 fuze, the delay composition is typically ignited by a thin layer of igniter composition—the input charge. At the other end of the

fuze, the delay composition ignites a second igniter—an output charge that ruptures the case and ignites the contents of the grenade attached to the fuze. The first igniter, A-1A, contains zirconium, red iron oxide, and diatomaceous earth. Due to stringent military requirements for the performance of A-1A igniter composition and the fine, powdered zirconium that it contains, manufacturers have found it challenging to produce or obtain this igniter in a form suitable for fuzes. The second igniter, the output charge, is a mixture of titanium and potassium perchlorate (TPP); it is objectionable due to the presence of the perchlorate salt.

The delay element of Figure 1 is not a vented design. The headspace is sealed by the case, the initiator, and the pyrotechnic compositions. The case and initiator are not designed to vent gases or gas pressure that may accumulate within the headspace while the input charge and delay composition burn. Gas pressure within the headspace may or may not be relieved once the output charge ignites. Whether this occurs or not depends on the porosity of the combustion products produced by the input charge and the delay composition. Nevertheless, the conventional protocol has been to use a “gasless” igniter (A-1A) as an input charge and an explosive one (TPP) as an output charge. This is partly because a gas-producing input charge could eject the initiator or prematurely rupture the case. In contrast, an output charge must produce some amount of gas to forcefully eject the hot combustion products and metal sparks required to ignite the pyrotechnic contents of a smoke grenade.

Surprisingly, mixing titanium, manganese dioxide, and PTFE can produce acceptable input and output charges for hand-grenade fuzes. The Ti/MnO<sub>2</sub>/PTFE composition produces

enough gas as an output charge to forcefully eject incandescent molten oxides and titanium sparks, yet the same composition may be used as an input charge without causing the ejection of percussion primers or premature rupturing of fuze cases [3].

## EXPERIMENTS

### Material Properties

The materials used in this study, all fine powders, were used as received. Vendor information, material specifications, and nominal particle sizes are shown in Table 1. Figures 2 and 3 are scanning electron micrographs of the titanium powder and manganese dioxide powder, respectively. The former was distinctly coarser than the latter.

### Preparation of Pyrotechnic Compositions

Igniter and delay compositions for fuze assembly and sensitivity tests were prepared by combining shaking and screening steps. Shaking was performed remotely with a Scientific Industries Vortex Genie. The dry powders were combined in conductive containers and shaken for 5 min, passed through a 100 mesh screen twice, and then shaken for another 5 min.

### Sensitivity Testing

Impact sensitivity tests were performed with a Bundesanstalt für Materialforschung und -prüfung (BAM) 5-kg drop hammer. A Chilworth BAM friction apparatus was used for friction sensitivity testing, and a Safety Management Services (Alleghany Ballistics Laboratory) apparatus tested electrostatic discharge (ESD) sensitivity. The reported values represented the greatest energy or force resulting in nonignition for 10 (impact and friction) or 20 (ESD) successive trials.

Table 1: Material Vendors, Specifications, and Nominal Particle Sizes

MATERIAL	VENDOR	SPECIFICATION	NOMINAL SIZE
Ti	Hummel Croton	>98.5%	-200 mesh
MnO <sub>2</sub>	Alfa Aesar	>99.9% (metals basis)	-325 mesh
KClO <sub>4</sub>	Hummel Croton	MIL-P-217A, grade A, class 4	~20 μm
PTFE	AGC Chemicals	Type FL1650, rounded particles	~17 μm
Flux-calcined diatomaceous earth	Alfa Aesar	Celite Hyflo Super-Cel	-150 mesh

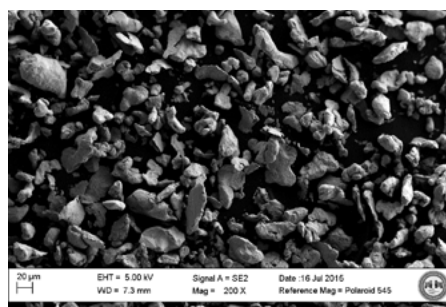

Figure 2: Scanning Electron Micrograph of Titanium Powder ( $\times 200$ ) (Source: CCDC Armaments Center).

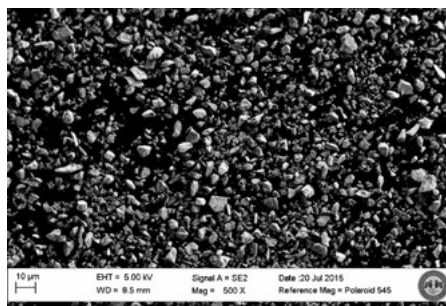

Figure 3: Scanning Electron Micrograph of MnO<sub>2</sub> Powder ( $\times 500$ ) (Source: CCDC Armaments Center).

### Thermochemical Calculations

Thermodynamic equilibrium calculations were performed with FactSage 7.0 [4]. FactPS, FToxid, and a custom database that included thermodynamic data for PTFE were used. The custom database was professionally built by The Spencer Group, Inc., using available

literature data [5]. All simulations assumed a constant pressure of 101.325 kPa, with the reactants initially at 298.15 K. Analyses performed in adiabatic mode ( $\Delta H = 0$ ) gave predicted adiabatic reaction temperatures ( $T_{ad}$ ) and the equilibrium products at those temperatures.

### Fuze Assembly and Testing

Each M201A1 or M213/M228 fuze was prepared by pressing an output charge, a delay composition, and an input charge into fuze hardware with a hydraulic press at 200 MPa. The pyrotechnic compositions were loaded and pressed in one to four increments, depending on the type of fuze. A percussion primer and primer holder (if necessary) were then fitted, and the aluminum delay case or zinc fuze body was crimped to secure them.

To perform each functioning test, a fuze was fitted with a hinge pin and striker and mounted in an insulated clamp attached to a rigid assembly. A steel weight was positioned approximately 60 cm above the fuze within a plastic tube and held in place by an electromagnet. The weight was dropped by turning off the power supply to the electromagnet. The action of the weight on the striker initiated the fuze by firing the percussion primer. The signature produced by the weight striking the

fuze was captured by an acoustic trigger (Kapture Group MD-1505 with transistor-transistor logic [TTL] output). The striking/initiating event caused the acoustic trigger to generate a 5-V TTL pulse used to activate an in-house-developed data collection system. The audible report produced by deflagration of the output charge generated a second TTL pulse. The time difference between the two pulses was used as the fuze functioning time. The accuracy of the method was verified with a high-speed video camera (Vision Research Phantom 7.1). The delay burning time most likely accounted for much of the functioning time, as the other events were rapid.

## RESULTS AND DISCUSSION

### Calculated Properties

Table 2 lists some calculated properties of five different igniter compositions. The first, IC-1, is known as A-1A. The second, IC-2, is known as TPP. Compositions IC-3, IC-4, and IC-5 are experimental. Calculated adiabatic reaction temperatures and the amounts of gas products predicted to form at those temperatures are presented. Here, chemical equilibrium is assumed. For example, IC-5 is expected to produce as much as 21.90 wt-% gas upon combustion. However, the actual combustion temperatures are likely to be lower because of heat lost to the surroundings, and the actual amounts of gas produced may vary. These calculations do not consider atmospheric interactions, which are relevant in certain fuel-rich systems such as the titanium-based ones in Table 2. However, the results provide useful and quantitative indications.

### Sensitivity Assessment

The sensitivities of the igniter compositions in Table 2 regarding

various ignition stimuli were determined and are shown in Table 3. They suggest that compositions IC-3, IC-4, and IC 5 should generally be safer to produce and handle than A-1A or TPP. Nonetheless, appropriate precautions should always be taken when preparing or handling pyrotechnic compositions. Overall, IC-5 appears to be the least sensitive of the five compositions.

### Pyrotechnic Chemistry and Gas Production

For many years, the A-1A igniter has been used as an input charge in fuzes. It produces a negligible amount of gas upon combustion. The hot condensed-

phase products formed, including molten iron, effectively ignite pyrotechnic delay compositions. However, it is unsuitable for use as an output charge because it does not produce enough gas. In contrast, TPP is explosive and produces a substantial amount of gas. Potassium chloride, volatile at pyrotechnic temperatures, is a primary constituent of the gas. The condensed-phase products include titanium oxides and excess titanium metal in the liquid state. Droplets or particles of titanium metal ejected from the combustion zone continue to burn in the air at a very high temperature. Generally, effective output charges produce an appropriate distribution of condensed-

Table 2: Calculated Properties of Igniter Compositions<sup>a</sup>

ENTRY	COMPONENTS	COMPONENT WEIGHT RATIOS	T <sub>ad</sub> (K) <sup>b</sup>	GAS PRODUCTS (wt-%) <sup>c</sup>
IC-1	Zr, Fe <sub>2</sub> O <sub>3</sub> , DE <sup>d</sup>	65/25/10	2951	0.67
IC-2	Ti, KClO <sub>4</sub>	70/30	3297	29.44
IC-3	Ti, MnO <sub>2</sub>	60/40	2336	6.44
IC-4	Ti, MnO <sub>2</sub> , DE <sup>d</sup>	60/35/5	2333	4.46
IC-5	Ti, MnO <sub>2</sub> , PTFE	60/35/5	2277	21.90

<sup>a</sup> Calculated using FactSage 7.0.

<sup>b</sup> Adiabatic reaction temperature.

<sup>c</sup> Amount of gas products at the adiabatic reaction temperature.

<sup>d</sup> Diatomaceous earth (DE) approximated as 95 wt-% SiO<sub>2</sub> and 5 wt-% Al<sub>2</sub>O<sub>3</sub>.

Table 3: Sensitivity Data for Igniter Compositions<sup>a</sup>

ENTRY <sup>b</sup>	IMPACT (J)	FRICTION (N)	ESD (mJ)
IC-1 <sup>c</sup>	>29.4	<4.4	<0.05
IC-2	29.4	60	2.5
IC-3	>31.9	240	8.8
IC-4	>31.9	>360	7.5
IC-5	>31.9	>360	31.0

<sup>a</sup> Greatest energy or force resulting in nonignition for 10 (impact, friction) or 20 (electrostatic discharge) successive trials.

<sup>b</sup> Entries refer to the igniter compositions in Table 2.

<sup>c</sup> Miklaszewski et al. [1] and Rose [6].

phase and gas-phase products upon combustion and the gas forcefully ejects the condensed-phase products (and excess metallic fuel, if present). While the presence of titanium in an output charge is not required, it is generally advantageous because an excess of the metal readily forms the aforementioned sparks, effectively igniting other pyrotechnic compositions.

In compositions IC-3, IC-4, and IC-5, the Ti/MnO<sub>2</sub> thermite system is predominant. DE is usually thought of as an inert material. However, in systems containing group 4 metals (titanium, zirconium, or hafnium), the formation of silicides is plausible. On the other hand, PTFE is undoubtedly reactive. The pyrotechnic chemistry of the Ti/MnO<sub>2</sub> and Ti/PTFE systems may be approximated by six representative chemical equations. Equations 1–3 are more likely to occur when the mixtures contain low titanium loadings or are deficient in titanium. Equations 4–6

correspond to high titanium loadings and are more likely to occur in titanium-rich mixtures. Excess titanium can also undergo combustion in the air, as shown by equation 7.

In these equations, at the anticipated temperatures of combustion, carbon and titanium carbide (C and TiC) are in the solid state, the titanium oxides are expected to be liquids, the manganese metal likely exists as a mixture of liquid and gas, and the titanium fluorides are certainly gases. Thus, it may be understood how adding PTFE to Ti/MnO<sub>2</sub> mixtures increases the amount of gas produced. Further, this can be achieved when titanium is present in excess, at loadings greater than about 50 wt-%. Note that the amounts of gas expected from IC-2 and IC-5 in Table 2 are quite similar.

### Open-Burning Properties

Ignition tests were conducted to reveal the pyrotechnic characteristics of the

titanium-based igniter compositions in Table 2. Piles of the unconsolidated compositions, each weighing 3 g, were ignited with an electrically-heated, nickel-chromium wire. Upon ignition, the piles burned rapidly, producing a bright white flash and a burst or spray of incandescent sparks. The most violent, rapid, and explosive event was produced by TPP (IC-2). The other compositions burned somewhat more slowly. In similar tests, the same compositions were consolidated into pellets weighing 1.5 g each. Igniting the pellets produced similar and analogous pyrotechnic events, although pellets of composition IC-3 could not be ignited by an electrically-heated wire. Figure 4 shows a series of images from an IC-5 pellet test where ignition was achieved with an electrically-heated nickel-chromium wire. All of the compositions, as piles or as pellets, burned rapidly in a general sense. The combustion events were complete within 1 s. Furthermore, the combustion rates are expected to increase when the compositions are confined within a metal housing. Gas-producing compositions generally burn more rapidly, or even explosively, when confined.

### Hand-Grenade Fuzes

Within a hand-grenade fuze, the input charge must possess mechanical integrity so that it does not

$Ti + MnO_2 \rightarrow TiO_2 + Mn.$	(35.5 wt-% titanium)	(1)
$4Ti + 3C_2F_4 \rightarrow 4TiF_3 + 6C.$	(39.0 wt-% titanium)	(2)
$2Ti + C_2F_4 \rightarrow 2TiF_2 + 2C.$	(48.9 wt-% titanium)	(3)
$2Ti + MnO_2 \rightarrow 2TiO + Mn.$	(52.4 wt-% titanium)	(4)
$10Ti + 3C_2F_4 \rightarrow 4TiF_3 + 6TiC.$	(61.5 wt-% titanium)	(5)
$4Ti + C_2F_4 \rightarrow 2TiF_2 + 2TiC.$	(65.7 wt-% titanium)	(6)
$2Ti + O_2 \rightarrow 2TiO.$		(7)



Figure 4: Open-Air Combustion of a 1.5-g Pellet of IC-5 (Source: CCDC Armaments Center).

disintegrate into the headspace during transportation or when the grenade is thrown. For this reason, the A-1A igniter has often been mixed and granulated with a small amount of vinyl alcohol-acetate resin. On the other hand, output charges do not necessarily require mechanical strength, especially in designs where they are sealed by the case (e.g., the M201A1 fuze). A binder is required for designs where the output charge is exposed. More importantly, binders, as reactive components or as additives, can allow the use of one formulation for both purposes.

The only composition in Table 2 that could plausibly fulfill both roles is IC-5. Here, PTFE is not only a critical reactive component but also a lubricant and dry binder. A small amount of PTFE can impart substantial mechanical strength to pressed mixtures of powdered materials. This was observed qualitatively when preparing the pellets for open-burning experiments.

The Ti/MnO<sub>2</sub>/PTFE igniter system was tested in M201A1 and M213/M228 configurations with Mn/MnO<sub>2</sub> and W/MnO<sub>2</sub> delay compositions. Mn/MnO<sub>2</sub> compositions tended to burn more quickly and were suitable for the M201A1 fuze, while the slower-burning W/MnO<sub>2</sub> system met the M213/M228

One benefit of using IC-5 as an input and output charge is that the delay composition need not contain any binder.

burning time requirements. Delay time data for experimental M213/M228 fuzes have been reported [2]. Successful results were also obtained in the M201A1 configuration and will be reported at a later date. Figure 5 illustrates the M201A1 fuze configuration.

One benefit of using IC-5 as an input and output charge is that the delay composition need not contain any binder. The igniter layers are mechanically sound and effectively secure the delay increments. In hand-grenade fuzes, an effective charge weight of IC-5 is ~60–70 mg. This ensures reliable ignition of the delay column and that a robust burst of sparks is produced after the specified interval. Critically, as an input charge, the Ti/MnO<sub>2</sub>/PTFE composition does

not cause primer ejection or premature case rupture, despite the fact that it produces a notable amount of gas upon combustion.

### Output Charge Characterization

One of the fuze output charge events was captured with a high-speed video camera operating at 250 frames per second (Figure 6). In this figure, an M201A1 fuze is held and secured by a clamp. Above the fuze, a steel weight rests within the transparent plastic tube that it was dropped through to initiate the test. The output charge creates a burst of incandescent reaction products and titanium sparks. The initial burst occurred rapidly, within 4 ms. In this particular example, the ejection and combustion of material from the fuze was mostly complete within ~60 ms. These bursting events are typically characterized by a bright sparky flash and an audible report.

### CONCLUSIONS

The Ti/MnO<sub>2</sub>/PTFE igniter may be used as an input and output charge in hand-grenade fuzes. Conventional igniter compositions A-1A and TPP are not required. As an input charge, the new igniter does not prematurely rupture fuze cases or eject percussion primers.



Figure 5: An M201A1 Fuze Body and Delay Case (Left), Top of an Assembled Fuze Showing the Primer (Middle), and Bottom of an Assembled Fuze Showing the Closed End of the Delay Case (Right) (Source: CCDC Armaments Center).

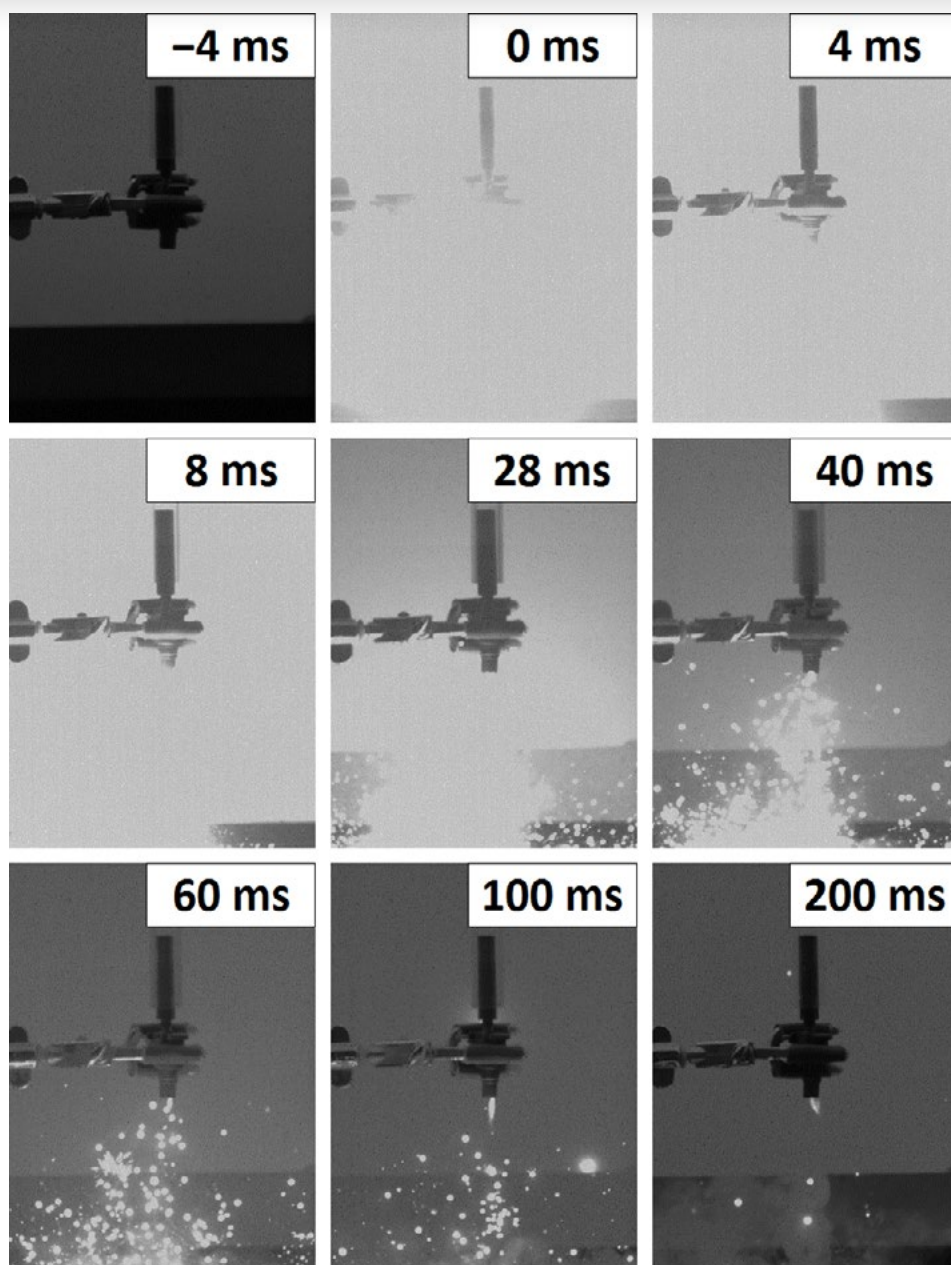

Figure 6: A Sequence of Images Showing Output Charge Combustion (Source: CCDC Armaments Center).

Yet, as an output charge, it produces a sparky burst similar to TPP. It may be prepared as a dry mixture, without any solvent-based processing steps. Thin, consolidated layers possess adequate mechanical strength. As a result, the delay compositions do not require any binder, as the igniter layers securely retain the delay increments. ■

## ACKNOWLEDGMENTS

Funding for this work was provided by the Strategic Environmental Research and Development Program, project number WP-2518, “Environmentally Sustainable Gasless Delay Compositions for Fuzes.” Robert A. Gilbert, Jr. (U.S. Army CCDC Armaments Center) is thanked for designing the tool sets for

fuze assembly, and Rajendra K. Sadangi (U.S. Army CCDC Armaments Center) is thanked for acquiring the scanning electron micrographs.

## REFERENCES

- [1] Miklaszewski, E. J., A. P. Shaw, J. C. Poret, S. F. Son, and L. J. Groven. “Performance and Aging of Mn/MnO<sub>2</sub> as an Environmentally Friendly Energetic Time Delay Composition.” *ACS Sustainable Chem. Eng.*, vol. 2, pp. 1312–1317, 2014.
- [2] Koenig, J. T., A. P. Shaw, J. C. Poret, W. S. Eck, and L. J. Groven. Performance of W/MnO<sub>2</sub> as an Environmentally Friendly Energetic Time Delay Composition. *ACS Sustainable Chem. Eng.*, vol. 5, pp. 9477–9484, 2017.
- [3] Shaw, A. P., J. C. Poret, L. J. Groven, J. Koenig, and J. S. Brusnahan. “Pyrotechnic Delay Element Device.” U.S. Patent Application 15/891,557, 8 February 2018.
- [4] Bale, C. W., A. D. Pelton, W. T. Thompson, G. Eriksson, K. Hack, P. Chartrand, S. Decterov, I. H. Jung, J. Melancon, and S. Petersen. *FactSage*, version 7.0; CRCT ThermFact Inc. and GTT-Technologies, 2015, <http://www.factsage.com>, accessed February 2018.
- [5] The Spencer Group, Inc. *FactSage Thermochemical Software and Consulting*, <http://www.spencergroupintl.com>, accessed February 2018.
- [6] Rose, J. E. “Properties of Energetic Materials Used in Ordnance Devices.” Special Publication IHSP 89-288, Naval Ordnance Station, Indian Head, MD, 1990.

## BIOGRAPHIES

**ANTHONY P. SHAW** has worked in the Pyrotechnics Technology Division of the U.S. Army CCDC Armaments Center, Picatinny Arsenal, NJ, since 2010. His research interests include the thermodynamics of energetic materials, the design of pyrotechnic systems, and high-temperature inorganic chemistry. Dr. Shaw holds a B.S. in chemistry from Rensselaer Polytechnic Institute and two master’s degrees and a Ph.D. in chemistry from Columbia University.

**JAY C. PORET** has worked in the Pyrotechnics Technology Division of the U.S. Army CCDC Armaments Center, Picatinny Arsenal, NJ, since 2003. His research interests include the development of environmentally-benign pyrotechnic compositions, combustion modeling, and optical measurement systems. Dr. Poret holds a B.S. in ceramic engineering from Rutgers University, an M.S.E. in materials engineering from the University of Alabama at Birmingham, and a Ph.D. in materials science from Johns Hopkins University.

**LORI J. GROVEN** is an assistant professor at the South Dakota School of Mines and Technology (SDSMT), Rapid City, SD. She was a member of the research faculty at Purdue University. Her research interests include advanced energetic materials, combustion synthesis, and additive manufacturing of energetic formulations. Dr. Groven holds B.S. and M.S. degrees in chemical engineering and a Ph.D. in nanoscience and nanoengineering from SDSMT.

**JOSHUA T. KOENIG** worked as an MS student in Dr. Groven’s laboratory at SDSMT from 2014 to 2016, where he studied the combustion of pyrotechnic delay compositions.

**JASON S. BRUSNAHAN, PH.D.**, Defence Science and Technology Group, Edinburgh, Australia, worked in the Armaments Center’s Pyrotechnics Technology Division as a visiting scientist under the auspices of the Engineer and Scientist Exchange Program from 2015 to 2016. During that time, he studied pyrotechnic illuminant, igniter, and incendiary compositions.



*(Photo Source: 123rf.com)*

# LASER POWER BEAMING

By Tom Nugent

## INTRODUCTION

Methods of wireless delivery of electric power have been discussed for over a century. Only in the last decade have such systems been brought to reality. Consumer devices to charge mobile phones and low-power devices within millimeters sell by the millions. These devices rely on induction or resonant near-field coupling.

Technologies for longer distances, often referred to as “power beaming,” are still in the product development phase. The general concept takes electricity from a point where it is plentiful and easily accessible (e.g., the power grid or a generator) and converts it into an electromagnetic field. It is then

“beamed” to a remote receiver that converts the electromagnetic power back into electricity. The two main technologies for power beaming use either microwave/millimeter-wave frequencies or near-infrared lasers. Compared to microwave beams, lasers have the advantage of much smaller apertures and no chance of radio frequency interference. Although the examples and components discussed here will involve laser power beaming, the general arguments also apply to microwave power beaming.

Figure 1 shows a schematic representation of a laser power-beaming system. Electric power, sourced from the grid or a generator, drives a laser (via its own direct-current [DC] power supply), chiller, and control electronics. The light is shaped by optics and then directed to the remote photovoltaic

(PV)-based power receiver, where it is converted into electricity. The PV electric output is converted and regulated via a power management and distribution system, which also handles recharging the device’s battery.

In the 20<sup>th</sup> century, lasers had very low efficiencies, and photovoltaic cells had not been optimized for monochromatic (laser) conversion. Great improvements in the last 20 years have been made—increasing the top efficiencies for both components above 60% and resulting in end-to-end efficiencies greater than 20% (a huge improvement that has made laser power beaming useful for a growing number of applications). Unfortunately, how efficiency is reported varies from group to group. As this field grows, researchers, designers, and end users will need to make “apples-to-apples” comparisons. In this article,

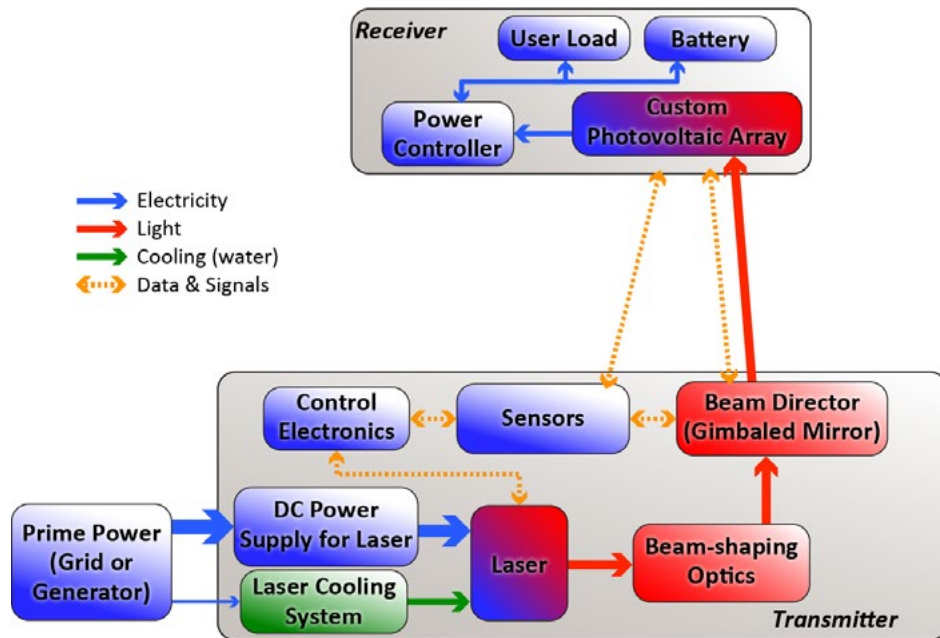

Figure 1: Simplified System Schematic for a Laser Power-Beaming System (Source: PowerLight Technologies).

The two main technologies for power beaming use either microwave/millimeter-wave frequencies or near-infrared lasers.

we describe the audience for efficiency numbers and the factors affecting efficiency and suggest some ways for common reporting.

## THE PROBLEM OF REPORTING EFFICIENCY

Historically, there has not been an agreed-upon definition of which elements to include and exclude when reporting efficiency for power-beaming systems. There are multiple audiences

for efficiency reporting, including end users, researchers, and system developers. Researchers focus on component-level efficiency. System developers care about the elements under their control, which might be a system or one or more subsystems. End users and purchasers care about the complete, “all in” (also called wall-plug) efficiency because they need to know how much input power is required to deliver the target output power.

While we discuss how to report efficiency, it is very important to realize that focusing only on electrical efficiency misses the point of using power beaming for many use cases. Every kind of power delivery has use cases where power beaming is the best choice, and others where it is not. Grid-scale (multimegawatt) power delivery is not (currently) an appropriate use case for power beaming except for the most remote, extreme cases. But there are numerous use cases in the 100–5,000-W range (averaged over 24 hours) where

efficiency is the least of the users’ concerns because of the inability or cost of running something like an extension cord. Assuming an electricity cost of \$0.10/kW-hour, delivering 5 kW remotely (at 20% wall-plug efficiency) would only cost roughly \$2.50/hour. Compare that cost to the time savings of personnel to change batteries, risk reduction when exposing Warfighters during a battery swap, and the benefit of increased sensor and communications coverage (e.g., from a “infinite” endurance unmanned aerial vehicle).

## FACTORS AFFECTING EFFICIENCY

Many elements factor into the cascade of efficiency losses in the flow of power through a system. Although we focus on laser power beaming, there are direct analogues for each component in microwave power beaming. The flow of power through a laser power-beaming system goes through the following elements:

- Source power (generator and wall outlet)
- Laser power supply (alternate current [AC]-to-DC)
- Chiller (including pump)
- Overhead electronics (controls, tracking, user interface [UI], etc.)
- Laser
- Optics
- Air or fiber (transmission medium)
- Uncaptured light (due to overflow of receiver)
- Receiver cover glass or optics
- Lost light (PV grid lines, inter-PV spacing, etc.)
- PV cells (affected by light intensity, temperature, etc.)
- Electric power output conversion and regulation
- Output power

The efficiency of any single element is determined by measuring the power

Focusing only on electrical efficiency misses the point of using power beaming for many use cases.

into the element and the power out. The tools for measuring power include voltmeter and ammeter, a calibrated shunt resistor with voltmeter to measure current (instead of an ammeter), optical power meter, and multiphase electrical meter/digital multifunction AC transducer. The efficiency measurement process is straightforward for components that have DC input and output. It can be more challenging when converting between AC and DC or when

converting between DC electric and optical power because of the differing uncertainties in the different measuring tools. For example, a calibrated voltmeter may have an accuracy of ~0.1%, whereas a calibrated high-power thermopile optical power meter may only have an accuracy of 3%.

Net efficiency can be calculated by multiplying the sequential component efficiencies together. Power beaming includes elements that require power but not in the direct power flow path, such as control electronics and a chiller.

The range of component efficiencies varies widely. AC-to-DC power supplies can get as high as ~94% but often are lower, with 80% not uncommon. Optical losses depend on the quality of coatings and polishing, with only 0.1% loss per surface achieved. Lasers range from 35% fiber lasers up to 65%+ diode lasers. PV cells also range from 25% up

to ~70%. Chillers have a coefficient of performance (CoP) that rates how much heat is transported away vs. the amount of input power. Current chillers exist with a CoP as high as 2.5, which would mean that to remove a given amount of heat, the chiller would require 40% of that value in input power. Work is being done on direct refrigerant cooling that could improve that performance significantly. In any of these cases, ambient conditions (especially temperature) also have a big impact on performance. Work on the laser side to reduce the amount of required cooling, which could allow a switch from chillers to forced air, is also being done.

A Sankey diagram is useful to visualize the flow of power. Using example values, we will discuss the varying types of impacts (e.g., scaling linearly, constant, etc.) on efficiency of different factors. Figure 2 shows an example power flow

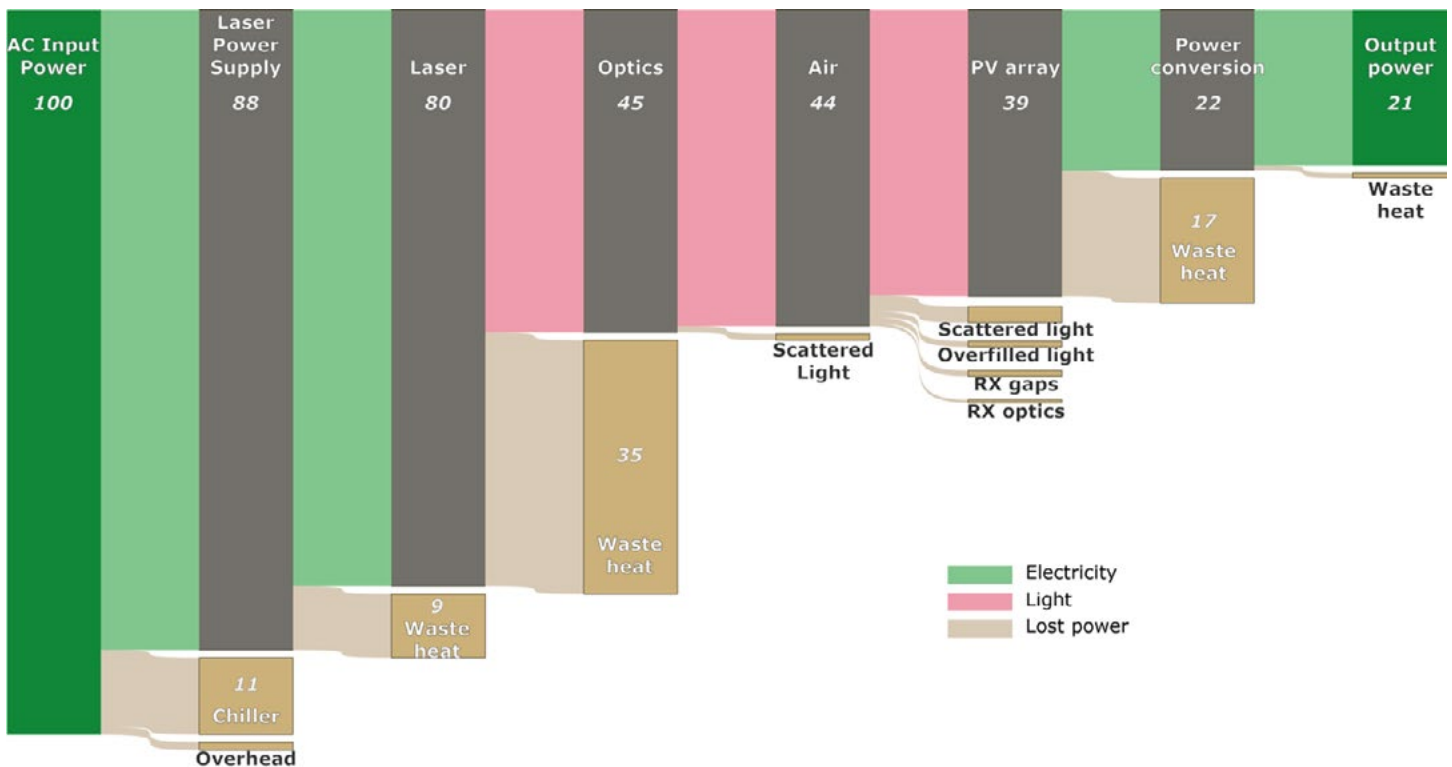

Figure 2: Sankey Diagram Example of Energy Flow Through a Power-Beaming System (Source: PowerLight Technologies).

diagram using component efficiency numbers that are chosen from within ranges of published values.

## EFFICIENCY EXAMPLES

There are a wide variety of options for what to include and not include in reporting an efficiency measurement. What *should* be included in a reported efficiency number? Those working on all or part of a power-beaming system are incentivized to publish a high number, whereas users and integrators desire accurate or conservative reporting (i.e., lower numbers). Furthermore, developers may only focus on one or a few subsystems.

The factors in efficiency fall in three broad categories—those for which power loss scales linearly with power, those where power losses are constant regardless of power, and those that depend on uncontrollable or unpredictable elements.

The components whose power loss scales linearly (or near linearly) with system power include the laser, PV receiver, baseline (best case) air and optics losses, and power supplies. Whether building a system to deliver 50 W or a different system to deliver 3,000 W, the current peak efficiency of diode lasers (or laser arrays) is still in the range of 60% (a 100-W laser would require 167 W of electric input, and a 4-kW laser would require 6.7 kW of electric power).

Some required components do not change noticeably in their power draw regardless of the power-beaming system scale. These are listed under “control electronics” and include system controls, UI, tracking electronics, and beam steering (the latter will scale with the size of the optics).

Finally, there are factors outside a system designer’s control. These factors

Some required components do not change noticeably in their power draw regardless of the power-beaming system scale.

are mainly atmospheric—humidity levels, air quality, and elevation. Table 1 outlines four cases where elements would and would not be included in efficiency reporting.

Case 1 would only include one or both of the major components, i.e., the laser and/or PV cells. This case is most relevant to researchers doing fundamental work on improving one of those components.

Case 2 would include all elements in the direct-power flow from DC power into the laser to the regulated DC power out. This case excludes the AC-to-DC power supply, chiller, and overhead electronics based on the perspective that those elements have widely-varying efficiencies. A developer might have a laboratory chiller that works fine for testing with a variety of lasers but is not efficiency-optimized for field use. This argument also applies to AC/DC power supplies. It can be more economical to use lab equipment that can handle a wide range of possible power levels instead of prematurely optimizing system components for which commodity modules exist for specific power levels.

Case 3 is similar to case 2 but adds in the chiller and removes the output power management elements. Because a chiller is a significant part of the power usage (accounting for 10%–20% or more of the total power draw), it gives

Table 1: Summary of Factors Included in Various Reporting Cases

	Case 1 (Major Components)	Case 2 (DC-In to Regulated DC-Out)	Case 3 (DC-In to Raw DC-Out + Chiller)	Case 4 (Everything)
Laser power supply	✗	✗	✗	✓
Laser	✓	✓	✓	✓
Chiller and pump	✗	✗	✓	✓
Overhead (electronics)	✗	✗	✗	✓
Optics	✗	✓	✓	✓
Air or fiber	✗	✓	✓	✓
Uncaptured light	✗	✓	✓	✓
Receiver optics	✗	✓	✓	✓
Lost light on RX	✗	✓	✓	✓
Photovoltaic cells	✓	✓	✓	✓
Power management	✗	✓	✗	✓

a better sense of system performance. Conversely, different customers will have different output power requirements (voltage level, allowed voltage range, etc.); therefore, a specific module should not be chosen for measuring efficiency.

Case 4 is the complete wall-plug-to-user-device-plug efficiency. This case is relevant when customers need to understand how much power is needed for the power-beaming system.

To report efficiency values for each of these cases, we use component efficiency numbers below peak-reported values but on the high end of existing ranges and assume a 5% loss in the atmosphere (equivalent to ~1 km in decent weather). Using medium-high efficiency values for each component, Table 2 summarizes the efficiencies reported in all of the cases. It is clear that the different reporting methods give a divergent impression of “the” efficiency.

Table 2: Summary of Efficiencies Reported Under a Variety of Cases

CASE	EFFICIENCY
1. Major components	31%
1a. Only one component	56%
2. DC-in to regulated DC-out	27%
3. DC-in to raw DC-out, plus chiller	24%
4. Everything (all-in)	21%

## METHODS PROPOSAL

In an ideal world, a single calculation could be used to report efficiency, and everyone would report that calculated number for their work. In reality, different audiences have different needs. Researchers and developers will care about the “important” effects but not overhead, whereas end users will care about how much power they have to supply to use the device. Therefore, we propose two options.

First, for published technical papers on system performance, we propose that system developers use the “DC-in to raw DC-out, plus chiller” method (with an option to call out the chiller efficiency separately). This enables them to include only the conditions directly under their control while ignoring factors that do not scale with power levels. Second, for specification sheets and research and development (R&D) proposals, we recommend that teams use the “everything (all-in)” method and state the conditions because end users need to know how much power to supply. In all cases, it is fair to assume clear air, and the reporting should call out the loss due to a specific (stated) distance. Regardless of how an efficiency number is reported, it is critical to clearly summarize what is and is not included.

## SUMMARY

We have seen how a wide range of efficiency values could be reasonably reported for the same system based on included factors. As power beaming moves toward commercialization, more people and groups will be involved in specifying, reviewing, and purchasing systems. It will be important for the industry to standardize common methods of reporting efficiency; otherwise, confusion from “apples-to-oranges” comparisons will slow down adopting this promising technology. We

As power beaming moves toward commercialization, more people and groups will be involved in specifying, reviewing, and purchasing systems.

recommend using the “DC-in to raw DC-out, plus chiller” efficiency method for research papers and the wall-plug (“everything [all-in]”) method for spec sheets and proposals. Regardless of what method is chosen, clearly explaining what factors are included in the efficiency measurement is important! ■

## BIOGRAPHY

**TOM NUGENT** is the chief technology officer and cofounder of PowerLight Technologies (PLT, formerly LaserMotive) and has been working on optical wireless power at PLT for over 10 years. Prior to PLT/LaserMotive, he was a project scientist at Intellectual Ventures Labs, a multidisciplinary early-stage R&D laboratory in Bellevue, WA. He was involved in the Photonic Fence project that used lasers to kill mosquitoes and other unpublished medical device projects. Mr. Nugent served as research director for LiftPort Inc. and worked on liquid-fueled rocket engine development at MIT. He holds a B.S. in physics from the University of Illinois at Urbana-Champaign and an M.S. in materials science and engineering from MIT.

# RANDOM ERROR

## IN SMALL- CALIBER DISPERSION

By Jeff Siewert

### OVERVIEW

**D**ispersion is the scatter in fall of shot at the target due to processes which may or may not be under the shooter's control. In general, there are two categories of error for small arms—bias errors and random errors. Figure 1 shows the effect of the two categories of errors of concern and illustrates the difference between random errors and bias errors on a target at range.

**Bias errors** displace the mean point of impact for a group of projectiles fired at the target from the intended impact point. Depending on the root source of the errors, the displacement of the mean point of impact can be in the horizontal plane, the vertical plane, or both planes. If the shooter or spotter can observe the fall of shot relative to the target, he or she can correct bias errors by displacing the aim point relative to the target.

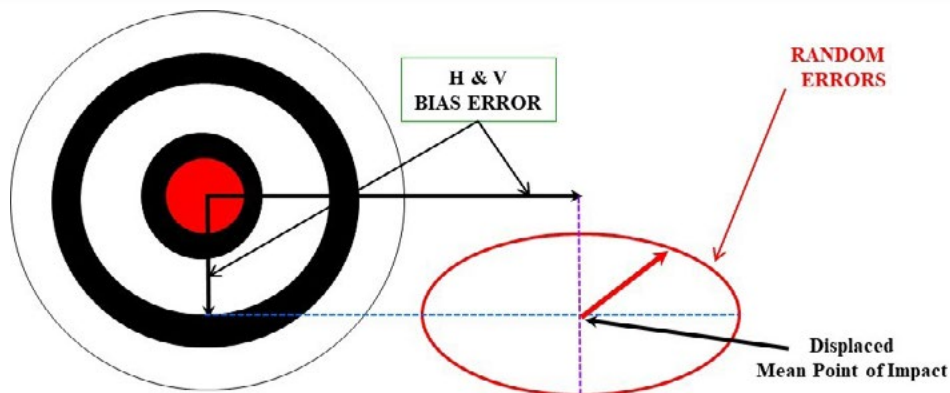

Figure 1: Random vs. Bias Error Illustration (Source: ArrowTech Associates, Inc.).

On the other hand, **random errors** cause scatter in the fall of shot about the displaced mean point of impact. Since these errors are random, the shooter cannot successfully correct errors in this category.

The projectile and cartridge/weapon interface factors create, or help create, a tilt of the projectile principal axis and a center of gravity (CG) offset regarding the bore centerline or, in some other way, induce a projectile angular rate or cross velocity at muzzle exit, or a combination of both. The variability in magnitude and direction of the vectors comprising the error budget results in dispersion. Figure 2 shows a notional error budget for two projectiles to illustrate the variability of error budget factors in magnitude and direction.

This article gives an overview of the dispersion error budget for small-caliber ammunition and identifies and quantifies the factors in the “random errors” portion of the dispersion error budget; due to space constraints, factors in the bias portion of the error budget are not covered. Factors comprising the random error budget include manufacturing defects, asymmetric engraving, the dynamic interaction between flexible bullet and a curved, flexible barrel, and blast field interactions. Bias error sources include

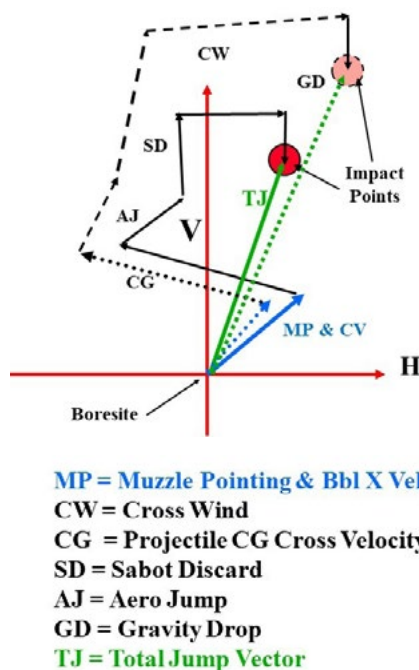

Figure 2: Notional Error Budget Vector Sum (Source: ArrowTech Associates, Inc.).

variability in winds, drag, muzzle velocity, and weapon cant.

### RANDOM ERROR BUDGET

The random error budget produces scatter of shot around a mean point of impact. Several general categories of random error attribute to the following:

- Manufacturing defects
- Asymmetric engraving
- Bullet-barrel interaction

- Bullet base – blast pressure at exit interaction
- Cartridge/weapon-related dispersion sources
- Factors related to exterior ballistics

Figure 3 shows a cross section of a projectile’s tilted axis and CG offset regarding the bore centerline.

The tilted principal axis of the projectile induces an angular rate at muzzle exit. It doesn’t matter if the angle is from a manufacturing defect in the projectile or the bullet happened to be asymmetrically engraved as it travels down the bore; an angular rate will be induced at muzzle exit. Equation 1, known as the “jump equation,” is used to provide estimates of projectile jump from boresight at reasonably short ranges if the constituent inputs are known or can be readily estimated.

$$\theta_j = \underbrace{\left(\frac{C_{Na} - C_{Dl}}{C_{ma}}\right)}_{\text{Aero Term}} \underbrace{\left(\frac{I_y - I_x}{m d^2}\right)}_{\text{Mass Prop. Term}} \underbrace{\left(\frac{d}{V_m}\right)}_{\text{“Scale” Term}} \underbrace{(a_g \times p_m)}_{\text{Angular Rate Term}} \mp \underbrace{\left(\Delta_{CG} \times \frac{p_m}{V_m}\right)}_{\text{Cross Vel. Term}}, \quad (1)$$

where

$\theta_j$  = projectile jump angle with respect to the barrel centerline,

$C_{Na}$  = normal force coefficient derivative per sine angle of attack,

$C_D$  = drag force coefficient,

$C_{ma}$  = pitching moment coefficient derivative per sine angle of attack,

$I_x$  = projectile polar moment of inertia,

$I_y$  = projectile transverse moment of inertia,

$m$  = projectile mass,

$\alpha_g$  = projectile angle in the tube, radians,

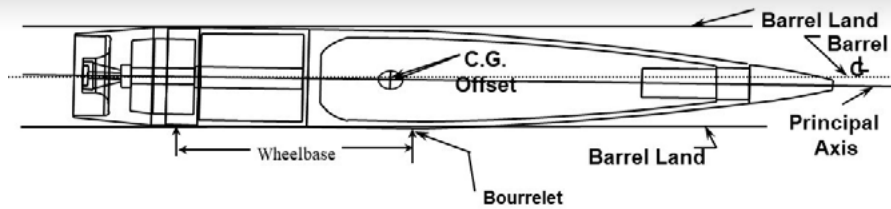

Figure 3: Illustration of Projectile Principal Axis Tilt and CG Offset (Source: ArrowTech Associates, Inc.).

$p_m$  = projectile exit spin rate, radians per second,

$d$  = projectile reference diameter,

$V_m$  = muzzle velocity, and

$\Delta_{CG}$  = radial distance from the tube centerline and the projectile CG.

The jump equation is useful in that it provides reasonably accurate estimates for projectile dispersion if the constituent factors are known or can be estimated. It is by no means all-encompassing; however, for most small- and medium-caliber, spin-stabilized projectiles, it is fairly accurate. Large-caliber, spin-stabilized projectiles (e.g., artillery and some naval guns) use ammunition with the projectile not rigidly affixed to the cartridge case. For these systems, gravity during the projectile ramming process results in a more consistent shot-to-shot initial position of the projectile regarding the bore centerline than would otherwise result if the projectile were crimped to a cartridge case. Thus, large-caliber, spin-stabilized projectiles shoot dispersion smaller than otherwise expected.

## BULLET-RELATED DISPERSION FACTORS

Bullet-related factors include the following:

- Manufacturing defects
- Asymmetric engraving
- Bullet-barrel interaction
- Bullet base – blast pressure at exit interaction

Each of these contributors will be briefly discussed next.

## MANUFACTURING DEFECTS

Manufacturing defects in small-caliber bullets arises from the inability of the projectile-forming machines (typically, transfer presses) to make perfect projectile components. For a standard “cup and core” projectile where a copper jacket is drawn into a cup and a dense metal with low-yield strength is subsequently pressed into the formed jacket cavity with the exterior of the jacket results in a principal axis tilt and CG offset. A given defect type will result in a linear relationship between these two factors, both of which cause dispersion. The CG offset and principal axis tilt multiplied by the bullet exit spin rate cause a “throw” and “aerodynamic jump” that cancel each other out, provided the bullet CG (mass) is forward of the midpoint of the projectile bourrelet [1]. For a typical small-caliber projectile with several categories of manufacturing defects, the dispersion depends on both distribution of defect type within the lot (e.g., 55% Defect A, 35% Defect B, and 10% Defect C) and the average magnitude and distribution of defect within defect type.

## ASYMMETRIC ENGRAVING

As the projectile jumps from the cartridge case to the forcing cone of the barrel, its central axis can tilt

Manufacturing defects in small-caliber bullets arises from the inability of the projectile-forming machines to make perfect projectile components.

regarding the bore centerline due to clearances between the bullet outside diameter and the barrel/chamber inside diameter. In this case, even if the bullet is perfectly made, it will have an induced angular rate at muzzle exit due to the in-bore angle arising from the asymmetric engraving. Figure 4 shows several sequential photos around the circumference of a single bullet, along with the measured engraved land length on a bullet, indicating engraving asymmetry.

If we take one half the difference between the maximum and minimum engraved length, divide by the average length, and then take the inverse tangent, we find that for the bullet, the engraving asymmetry caused an in-bore angle of approximately 0.38 deg. While this is a rather small angle, it is likely to have been an order of magnitude larger than any manufacturing defect that may have been present for this projectile; hence, the engraving asymmetry dominates the dispersion calculations.

## BULLET-BARREL INTERACTION

Bullet-barrel interaction is a broad, catch-all type category that includes, but is not limited to, the following:

- Dynamic interaction between a flexible projectile and a curved, flexible gun tube.



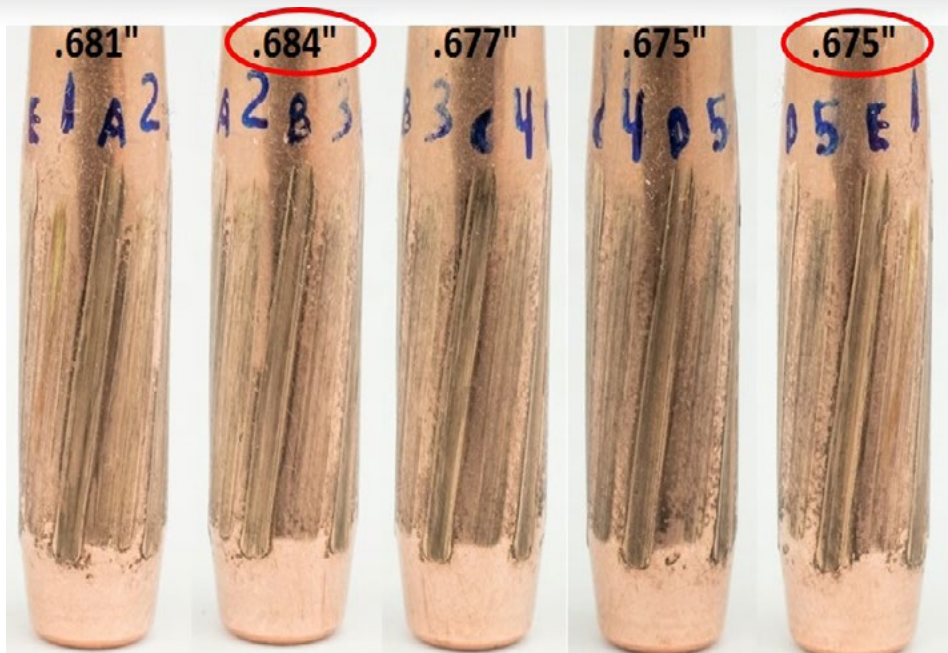

Figure 4: Example of an Asymmetrically Engraved Bullet (Source: ArrowTech Associates, Inc.).

- Interface between the projectile exterior and the various land geometries available.
- Free run to the forcing cone/engraving asymmetry.

The dynamic interaction between a flexible projectile and a curved, flexible gun tube causes variability in bullet exit states (cross velocity and angular rate) shot to shot. The projectile exit state's variability arises from three sources. One source is minor differences in bullet initial conditions at first motion, both in in-bore angle magnitude and initial pointing of the weapon (around the clock as viewed from the breech). A second source is from changes in the interior ballistic-forcing function's shot to shot affecting the peak's in-bore deflection of the projectile structure. Shot-to-shot variation in the in-bore angle occurs as a result, even if the initial orientation of the projectile is consistent. A third source of projectile exit state variability is from asymmetric loads applied to the barrel structure by forcing the bullet to travel a curved path, causing barrel

transverse motion (i.e., bore centerline pointing changes).

Figure 5 shows the "normalized" short-range dispersion observed and dispersion variation for a typical 30-cal match projectile as a function of exit twist and barrel land geometry fired from a precision weapon. The "reference"

system dispersion performance is shown in the middle of the far right-hand side of the plot, the "mean" dispersion at 1.0 for the 40-cal/revolution twist rate (1/12-inch twist). If bullet CG offset and principal axis tilt were the major causes of dispersion for this system, the observed average dispersion should follow the green line diagonally upward to the left as the twist increases. Instead, the observed mean dispersion for the "standard land" barrel (solid red line) slightly decreases as the twist increases from 1/12 inch to 1/10 inch and starts upward only as the barrel twist increases from 1/10 inch to 1/8 inch.

Interestingly, the barrels with "polygonal" rifling geometry shoot somewhat smaller mean dispersion than the "standard" land geometry, with slightly larger variability in the 1/10-inch twist barrel. However, in the 1/8-inch twist, the polygonal barrel shoots only slightly larger average dispersion, but the dispersion variability reduces compared to the polygonal land dispersion performance in the 1/10-inch twist barrel.

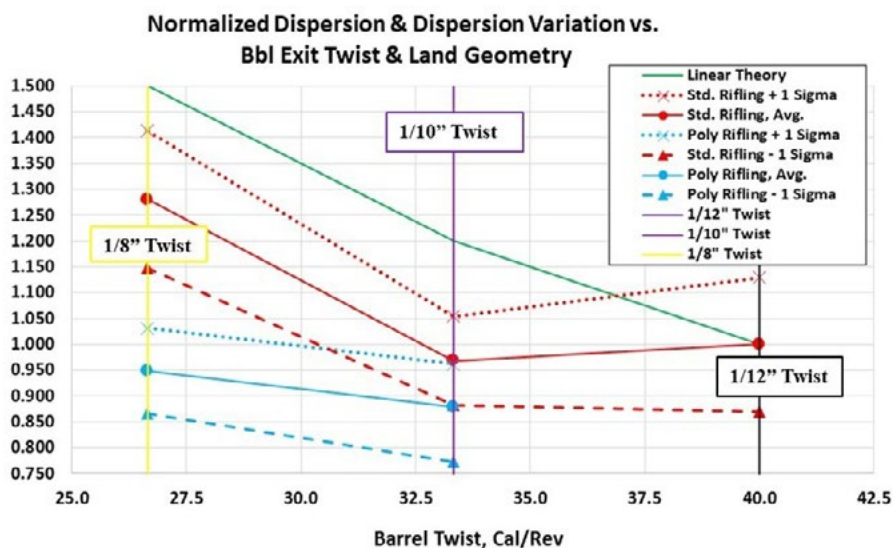

Figure 5: Normalized Mean Dispersion and Dispersion Variation vs. Barrel Exit Twist and Land Geometry (Source: U.S. Government).

The barrels with “polygonal” rifling geometry shoot somewhat smaller mean dispersion than the “standard” land geometry.

## BULLET BASE – BLAST PRESSURE AT EXIT INTERACTION

Figure 5 shows that the dispersion is not purely linear with twist rate for the standard land barrel, so there must be an alternate root cause of projectile dispersion at this performance level. It was hypothesized that a source of dispersion may be from angular rate induced on the bullet by interacting a minor base asymmetry with the blast field at muzzle exit; this might not be sensitive to barrel exit twist. Immediately after muzzle exit, the bullet is in a region of supersonic “reverse flow,” where dynamic pressure from barrel emptying is very high due to the high-velocity gas. Interaction between this high-velocity gas flowing by the projectile and any asymmetry in the projectile can be a root cause of dispersion.

Figure 6 shows the flow field that develops at the gun muzzle immediately after bullet exit from the tube, along with the “Mach Disk” and the region of supersonic gas flow from barrel emptying.

From previous studies on the flight of spin-stabilized bullets subjected to externally applied, asymmetric loads,

maximum flight path deviation occurred with an asymmetric load applied for half a bullet revolution. Extending load application past 180 deg of bullet rotation partially cancelled the early portion of the input load.

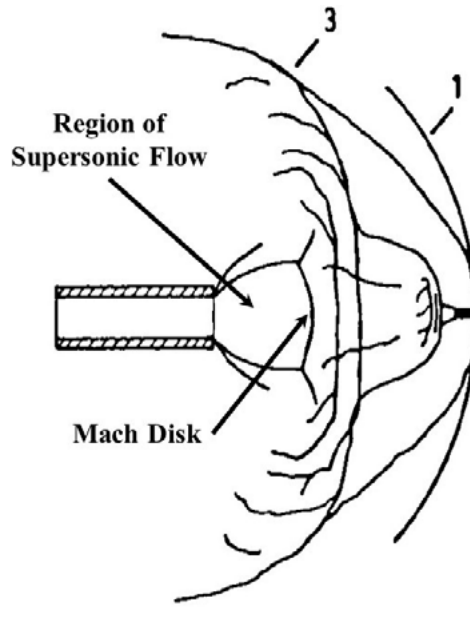

Figure 6: Muzzle Exit Flow Field Just After Muzzle Exit (Source: Klingenberg and Heimerl [2]; Reprinted by Permission of the American Institute of Aeronautics and Astronautics [AIAA, Inc.].)

Data in Figure 7 were generated from a bullet launched from a 308 Winchester case at approximately 800 m/s. Therefore, functions published in “Phenomenology of Gun Muzzle Flow” [2] were used to estimate the location of the “Mach Disk” in time at a travel distance of 6 inches, half the nominal twist rate of the 1/12-inch twist barrel. Working through the numbers, it appears this bullet will clear the Mach Disk at about 0.18 ms.

ArrowTech’s CONTRAJ body-fixed, six degrees of freedom trajectory code was used to investigate whether blast pressure at muzzle exit could cause the observed dispersion. To assess this hypothesis, an arbitrarily selected 5-N load (simulating gas interaction with a minor flaw in the bullet boat tail) was applied at the middle of the projectile’s boat tail length (as shown in Figure 8) for the following conditions:

1. A 180-deg (1/2-revolution) rotation for the 1/12-inch twist barrel, 0.18-ms duration.

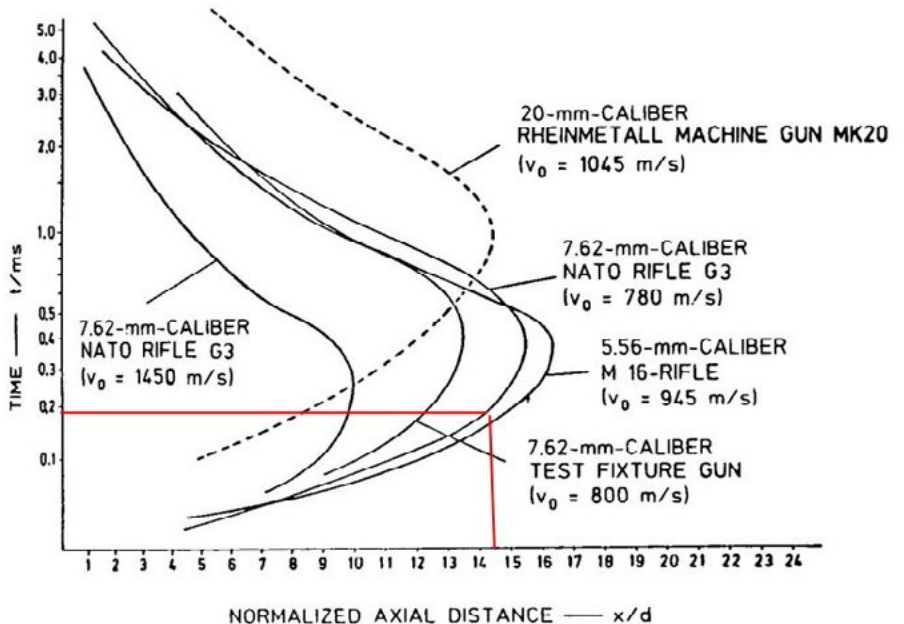

Figure 7: Mach Disk Location vs. Time for 7.62-mm Cartridge (Source: Klingenberg and Heimerl [2]; Reprinted by Permission of AIAA, Inc.).

2. A 225-deg (5/8-revolution) rotation for the 1/10-inch twist barrel, 0.18-ms duration.
3. A 270-deg (3/4-revolution) rotation for the 1/8-inch twist barrel, 0.18-ms duration.

A schematic of the externally applied load, representing the interaction of the barrel emptying flow with a minor flaw in the boat tail exterior of the bullet as it flies out through the Mach Disk, is shown in Figure 8.

Two facets of the induced-flight motion caused by the asymmetric applied load on a bullet fired from barrels with different twist rates were examined—the projectile total angle of attack (AlphaBar) as a function of range (Figure 9) and the drop and drift of the projectiles vs. range (Slant) (Figure 10).

Not unexpectedly, Figure 9 shows that the increased gyroscopic stability provided by the faster twist barrels, combined with the partial cancelling effect of extending the applied load past 1/2 revolution, leads to smaller induced maximum yaw levels with the faster twist barrels. The first maximum yaw for the 1/12-inch twist barrel is approximately 1.82 deg, 1.1 deg for the 1/10-inch twist barrel, and 0.75 deg for the 1/8-inch twist barrel.

This observation indicates that there will likely be less drag variability at launch from the blast pressure, asymmetry dispersion source. Interestingly, that is, in fact, what has been observed via Doppler radar during testing with barrels chambered for the same cartridge but manufactured with differing twist rates. However, the dispersion effect of a reduction in launch drag variability can only be observed experimentally at very long ranges.

As seen in Figure 10, once the bullets have flown about 70 m or so, the

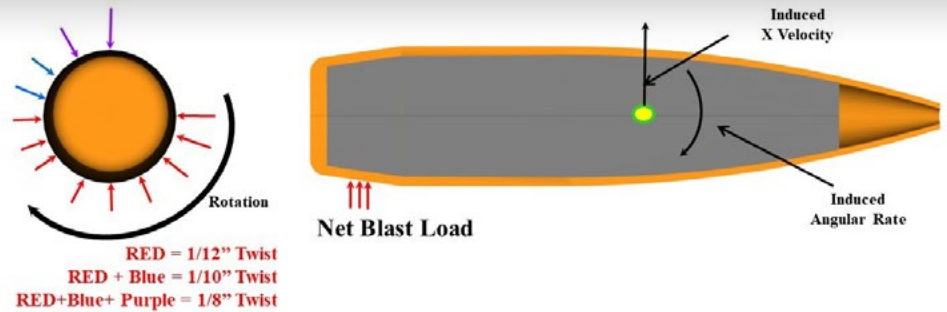

Figure 8: Asymmetric Load Application on the Projectile's Boat Tail (Source: ArrowTech Associates, Inc.).

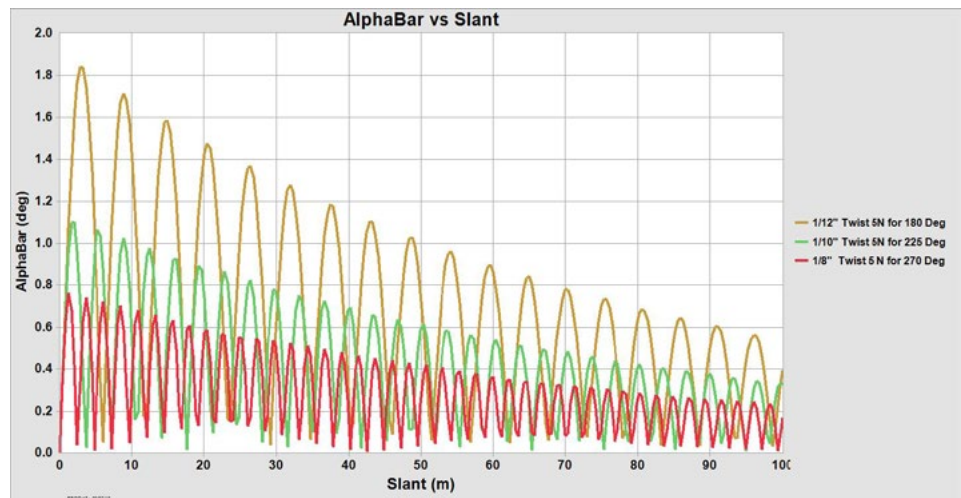

Figure 9: Angle of Attack vs. Range for Small-Caliber Bullet w/ Asymmetric Applied Load and Various Barrel Exit Twists (Source: ArrowTech Associates, Inc.).

drop and drift caused by an externally applied impulse of fixed time duration is essentially the same for bullets fired from each barrel, regardless of the barrel twist. While this is not proof that blast asymmetry is the root cause of the observed dispersion behavior shown in Figure 5 with increasing barrel twist (e.g., lack of linearly increasing group size with increasing twist rate), it is a plausible explanation for the observed lack of linear dispersion with increasing barrel twist.

## CARTRIDGE-/WEAPON-RELATED DISPERSION SOURCES

The barrel can be thought of as hollow tube with a fixity at the chamber/receiver end (for a bolt action sniper

weapon with a “free-floated” barrel). If the barrel is not perfectly straight, bullet passage through the barrel causes the bullet to accelerate in a direction perpendicular to the bore axis. These lateral accelerations impose loads on both the bullet and the barrel, and the two bodies each vibrate in response to these applied loads. Since the barrel is essentially a beam element, the forced vibration imposed by bullet passage is typically expected to impose loads and deflections of consistent magnitude and direction shot to shot. However, interaction between the barrel structure and the variable pressure-time forcing function behind the projectile results in minor changes in barrel pointing and cross velocity as the bullet exits the muzzle.

## CARTRIDGE

Minor differences in propellant weight, bullet weight, engraving force profile, chamber volume, free run to the rifling, and shot start pressure cause shot-to-shot variations in the attained peak chamber pressure and resulting muzzle velocity. Figure 11 shows the variability in pressure-travel performance for a typical 30-cal cartridge.

The variation in shot-start pressures and in-bore travel time causes the barrel to point in a slightly different direction and have a slightly different cross velocity for each shot at bullet exit from the muzzle, contributing to dispersion. For high-quality barrels, this shot-to-shot variation is small, and it is the reason shooters are willing to pay more for a high-quality barrel.

Free floating the barrels has the following two beneficial effects when it comes to keeping group sizes small:

1. It reduces the first bending mode frequency of the structure, making it easier to avoid resonance between projectile spin and barrel bending.
2. It prevents barrel thermal expansion from firing multiple shots in rapid succession and significantly altering the barrel pointing vector.

## WEAPON

Several weapon factors can influence the dispersion of ammunition, most of which are related to the interface between the bullet and the barrel. Figure 12 shows a comparison of bourrelet length for a typical match bullet for a barrel with a 0.3013-inch-diameter land and one with a 0.2980-inch-diameter land. The barrel with the smaller land diameter provides a longer bourrelet (~7% longer) and a smaller in-bore angle for the bullet when a fixed in-bore clearance between the

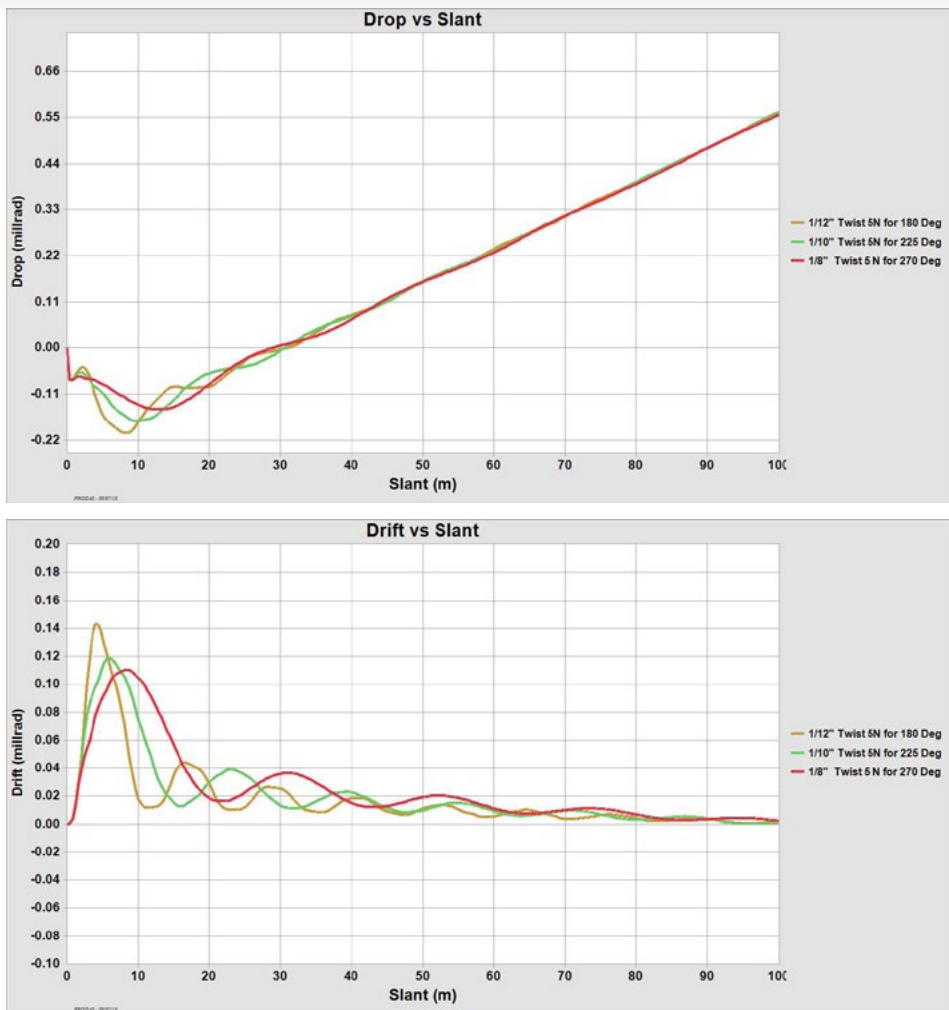

Figure 10: Drop and Drift vs. Range for Small-Caliber Bullet With Asymmetric Applied Load and Various Barrel Exit Twists (Source: ArrowTech Associates, Inc.).

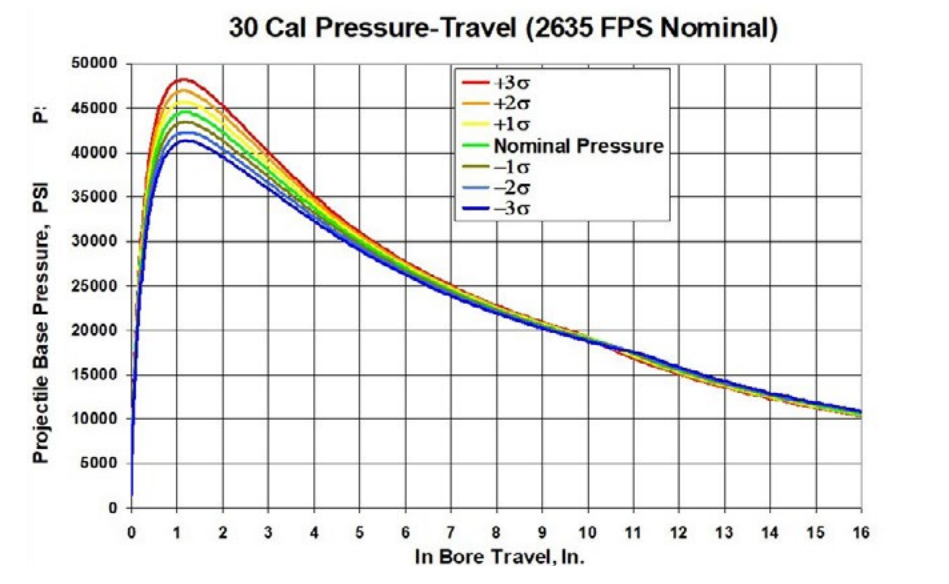

Figure 11: Mean and Sigma of Pressure Time for 30-cal Projectile (Source: ArrowTech Associates, Inc.).

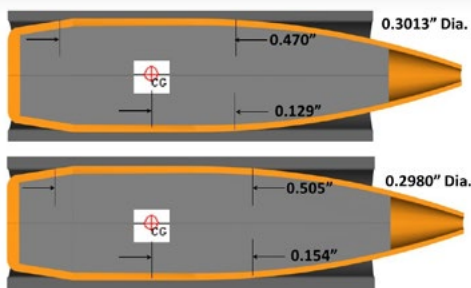

Figure 12: Comparison of Bourrelet Length vs. Land Diameter (Source: ArrowTech Associates, Inc.).

bullet bourrelets and the barrel lands is assumed. As seen in Equation 1, projectiles fired with smaller in-bore angles are expected to exhibit smaller aerodynamic jump—all else are equal.

Since there must be clearance between the interior dimensions of the weapon chamber and the exterior dimensions of the cartridge case to ensure the bolt will close on the chambered ammunition, it is nearly impossible to have the projectile centerline precisely aligned with the bore centerline as the cartridge is chambered. (This condition is illustrated in Figure 13.)

Fortunately for the shooter, the projectile can act in a sufficiently elastic manner to provide a “self-centering” alignment as it starts moving down the barrel, provided “free run” to the rifling is short and the pressures/accelerations at the start of engraving are reasonably low.

As the bullet makes the jump from the cartridge case into the barrel-forcing cone, the details of the projectile

structure, the materials from which the bullet structure is comprised, and the stress-strain behavior of projectile materials all play a part in the ultimate plastic deformation of the projectile structure and symmetry. For lead core-copper jacketed bullets, the stresses in the jacket can be quite high early in the in-bore travel, leading to asymmetric yielding of the jacket. For this reason, lead core-copper jacket bullets typically shoot smallest dispersion when the bullets are loaded very close to the barrel lands. This limits plastic deformation of the projectile structure early in the in-bore travel as the bullet does not have to move very far for the barrel to provide structural support to the projectile structure.

On the other hand, monolithic copper projectiles can tolerate a bit more “free run” to the rifling than a lead core-copper jacketed bullet because the density of projectile body is much lower than lead and the yield strength is considerably higher than lead. As a result, monolithic copper bullets typically shoot the smallest dispersion, with free run of about 0.020–0.050 inches (0.5–0.13 mm).

## SUMMARY

The factors affecting small-caliber bullet dispersion as a result of sources originating during projectile travel while inside the barrel have been identified and discussed. All the dispersion

sources discussed so far influence the “random” portion of the error budget. For random dispersion sources, all these effects must be added up in a root-sum-square manner to estimate the group size at range unless error source measurement resolution is unavailable to all but the most exacting test facilities.

The angular rate induced by interaction between the flow field created by barrel emptying and any bullet base asymmetries is expected to show very limited sensitivity to the barrel exit twist due to the fixed time duration of asymmetric load impulse application and the flight dynamics of the projectile in response to increased exit spin rates. Dispersion from this error source is typically only visible to the shooter at the very smallest dispersion levels.

The relative magnitudes of each of these errors depend on many factors, some under the direct control of the bullet maker, some affected by the ammunition maker, and some affected by the barrel/weapon maker. The manufacturers of each component of the weapon system must do their part to make the total system error as small as possible to successfully push the system hit probability as high as possible. ■

## REFERENCES

- [1] McCoy, R. *Modern Exterior Ballistics*. Atgen, PA: Schiffer Publishing, pp. 252–267, 1999.
- [2] Klingenberg, N., and J. M. Heimerl. “Phenomenology of Gun Muzzle Flow.” *In Gun Muzzle Blast and Flash*, AIAA, vol. 139, 1992.

## BIOGRAPHY

**JEFF SIEWERT** has worked as a systems engineer with ArrowTech Associates, Inc., for the past 29 years, working on projectiles ranging from 17-cal air rifle pellets to an 8-inch howitzer. He has taught numerous classes on ArrowTech’s PRODAS software at government and industry locations worldwide. He is a hunter and shooter and has been a reloader since 1983. Mr. Siewert holds a B.A. in physics from SUNY Oswego, New York.

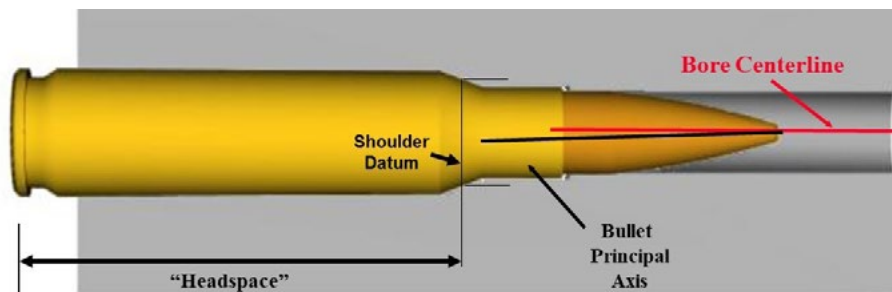

Figure 13: Bullet-Bore Centerline Alignment Comparison (Source: ArrowTech Associates, Inc.).

# Discover the **value** of sharing your **DoD-funded research...**

Maximize R&D dollars,  
foster collaboration

Advance industry  
innovation

Increase peer citations and  
worldwide dissemination

Leverage results of  
defense-funded research

Ensure long-term availability  
and preservation of documents

**SUBMIT**  
your research  
today!

**R&E Gateway** Powered by DTIC  
<https://go.usa.gov/xEe7Q>

## CONFERENCES AND SYMPOSIA

### MAY 2019

#### The Conference on Lasers and Electro-Optics Conference

5–10 May 2019  
The San Jose McEnery Convention Center  
San Jose, CA  
<https://www.cleoconference.org> ▶

#### 2019 MSS Active E-O Systems & Electro-Optical & Infrared Countermeasures (IRCM) Conference

7–9 May 2019  
Los Angeles, CA  
<https://mssconferences.org/public/meetings/conferenceDetail.aspx?enc=fVrcqIBZPHY0XrH1a%2BTb0Q%3D%3D> ▶

#### 2019 DEFENSE Forum

7–9 May 2019  
Kossiakoff Center at Johns Hopkins University Applied Physics Laboratory  
Laurel, MD  
<https://defense.aiaa.org> ▶

#### 62nd Annual Fuze Conference

13–15 May 2019  
Hyatt Regency Buffalo Hotel and Conference Center  
Buffalo, NY  
<http://www.ndia.org/events/2019/5/13/62nd-annual-fuze-9560> ▶

#### SAMPE 2019: An Advanced Materials and Processes Conference and Exhibition

20–23 May 2019  
Charlotte Convention Center  
Charlotte, NC  
<https://www.nasampe.org/events/EventDetails.aspx?id=904362> ▶

#### 2019 LANPAC Symposium & Exposition

21–23 May 2019  
Sheraton Waikiki  
Honolulu, HI  
<http://ausameetings.org/lanpac2019> ▶

### JUNE 2019

#### 2019 Armament Systems Forum

3–6 June 2019  
Fredericksburg Expo & Conference Center  
Fredericksburg, VA  
<http://www.ndia.org/events/2019/6/3/2019-armament-systems-forum> ▶

#### 2019 Joint Army-Navy-NASA-Air Force (JANNAF) meeting

3–7 June 2019  
Dayton Convention Center  
Dayton, OH  
<https://www.jannaf.org/mtgs/2019June/pages/index.html> ▶

#### Optical Sensors

25–27 June 2019  
McEnery Convention Center  
San Jose, CA  
[https://www.osa.org/en-us/meetings/osa\\_meetings/optical\\_sensors\\_and\\_sensing\\_congress/program/optical\\_sensors](https://www.osa.org/en-us/meetings/osa_meetings/optical_sensors_and_sensing_congress/program/optical_sensors) ▶

#### International Armored Vehicles USA

25–27 June 2019  
Four Seasons Hotel  
Austin, TX  
[https://internationalarmoredvehiclesusa.iqpc.com/?utm\\_medium=portal&mac=IQPCCORP](https://internationalarmoredvehiclesusa.iqpc.com/?utm_medium=portal&mac=IQPCCORP) ▶

#### Directed Energy Systems 2019

26–28 June 2019  
Washington, DC  
[https://distributedlethality.iqpc.com/?utm\\_medium=portal&mac=IQPCCORP](https://distributedlethality.iqpc.com/?utm_medium=portal&mac=IQPCCORP) ▶

### JULY 2019

#### The Wright Dialogue with Industry

16–18 July 2019  
Dayton Convention Center  
Dayton, OH  
<http://www.wrightdialogue.org> ▶

### AUGUST 2019

#### 2019 Propulsion Energy Forum

19–22 August 2019  
JW Marriott  
Indianapolis, IN  
<https://propulsionenergy.aiaa.org> ▶

### SEPTEMBER 2019

#### Air Vehicle Technology Symposium 2019

10–12 September 2019  
Dayton Convention Center  
Dayton, OH  
<http://www.avtechsymposium.com> ▶

#### Robotics and Autonomous Systems

23–25 September 2019  
Detroit, MI  
[https://roboticsautonomoussystemsiqpc.com/?utm\\_medium=portal&mac=IQPCCORP](https://roboticsautonomoussystemsiqpc.com/?utm_medium=portal&mac=IQPCCORP) ▶

#### Disruptive Technology for Defence Transformation

24–25 September 2019  
Hilton London Canary Wharf  
London, UK  
[https://disruptivetechdefence.iqpc.co.uk/?utm\\_medium=portal&mac=IQPCCORP](https://disruptivetechdefence.iqpc.co.uk/?utm_medium=portal&mac=IQPCCORP) ▶

#### Advanced Solid State Lasers Conference

29 September–3 October 2019  
Austria Center Vienna  
Vienna, Austria  
[https://www.osa.org/en-us/meetings/osa\\_meetings/laser\\_congress](https://www.osa.org/en-us/meetings/osa_meetings/laser_congress) ▶

**For more events, visit:**

[dsiac.org/resources/events](https://dsiac.org/resources/events) ▶



Defense Systems  
Information Analysis Center

4695 Millennium Drive  
Belcamp, MD 21017-1505

# DSIAC ONLINE

[www.dsiac.org](http://www.dsiac.org)

## DSIAC PRODUCTS AND SERVICES INCLUDE:

- Performing literature searches.
- Providing requested documents.
- Answering technical questions.
- Providing referrals to subject-matter experts (SMEs).
- Collecting, electronically cataloging, preserving, and disseminating Defense Systems scientific and technical information (STI) to qualified users.
- Developing and deploying products, tools, and training based on the needs of the Defense Systems community.
- Fostering and supporting the DSIAC technical Communities of Practice.
- Participating in key DoD conferences and forums to engage and network with the S&T community.
- Performing customer-funded Core Analysis Tasks (CATs) under pre-competed IDIQ Delivery Orders.

## DSIAC SCOPE AREAS INCLUDE:

- Advanced Materials
- Autonomous Systems
- Directed Energy
- Energetics
- Military Sensing
- Non-Lethal Weapons
- Reliability, Maintainability, Quality, Supportability, and Interoperability (RMQSI)
- Survivability and Vulnerability
- Weapon Systems



CONNECT WITH US ON SOCIAL MEDIA!